

University of Windsor

Scholarship at UWindor

Electronic Theses and Dissertations

Theses, Dissertations, and Major Papers

2011

Data Acquisition System For Fingerprint Ultrasonic Imaging Device

Moeen ud Din
University of Windsor

Follow this and additional works at: <https://scholar.uwindsor.ca/etd>

Recommended Citation

Din, Moeen ud, "Data Acquisition System For Fingerprint Ultrasonic Imaging Device" (2011). *Electronic Theses and Dissertations*. 146.

<https://scholar.uwindsor.ca/etd/146>

This online database contains the full-text of PhD dissertations and Masters' theses of University of Windsor students from 1954 forward. These documents are made available for personal study and research purposes only, in accordance with the Canadian Copyright Act and the Creative Commons license—CC BY-NC-ND (Attribution, Non-Commercial, No Derivative Works). Under this license, works must always be attributed to the copyright holder (original author), cannot be used for any commercial purposes, and may not be altered. Any other use would require the permission of the copyright holder. Students may inquire about withdrawing their dissertation and/or thesis from this database. For additional inquiries, please contact the repository administrator via email (scholarship@uwindsor.ca) or by telephone at 519-253-3000ext. 3208.

DATA ACQUISITION SYSTEM FOR FINGERPRINT ULTRASONIC IMAGING
DEVICE

By

Moeen ud Din

A Thesis
Submitted to the Faculty of Graduate Studies
Through the Department of Electrical and Computer Engineering
In Partial Fulfillment of the Requirements for
The Degree of Master of Applied Science at the
University of Windsor

Windsor, Ontario, Canada

2011

©2011 Moeen ud Din

DATA ACQUISITION SYSTEM FOR FINGERPRINT ULTRASONIC IMAGING
DEVICE

By

Moeen ud Din

APPROVED BY:

Dr. Gary W. Rankin
Department of Mechanical, Automotive and Materials Engineering

Dr. Huapeng Wu
Department of Electrical and Computer Engineering

Dr. Roman Maev
Department of Physics

Dr. Fedar Severin
Department of Physics

Dr. Rashid Rashidzadeh, Chair of Defense
Department of Electrical and Computer Engineering

May 16, 2011

DECLARATION OF ORIGINALITY

I hereby certify that I am the sole author of this thesis and that no part of this thesis has been published or submitted for publication.

I certify that, to the best of my knowledge, my thesis does not infringe upon anyone's copyright nor violate any proprietary rights and that any ideas, techniques, quotations, or any other material from the work of other people included in my thesis, published or otherwise, are fully acknowledged in accordance with the standard referencing practices.

Furthermore, to the extent that I have included copyrighted material that surpasses the bounds of fair dealing within the meaning of the Canada Copyright Act, I certify that I have obtained a written permission from the copyright owner(s) to include such material(s) in my thesis and have included copies of such copyright clearances to my appendix.

I declare that this is a true copy of my thesis, including any final revisions, as approved by my thesis committee and the Graduate Studies office, and that this thesis has not been submitted for a higher degree to any other University or Institution.

ABSTRACT

Ultrasonic imaging of fingerprint is relatively new application in the field of Biometrics that is capable of obtaining fingerprint pattern for identification purposes. In previous digital data acquisition system, image of the skin-plate contact pattern have been produced. Unfortunately, these systems do not provide any information about in-depth structure of the fingerprint area.

In this work, data acquisition system for ultrasonic imaging of fingerprint was developed with in-depth imaging capability. In this system finger is inserted into a hollow cylinder and set of rotating focused ultrasonic transducers scans over the finger. Emitting and receiving of ultrasonic signal is realized by the DSP-based data acquisition board.

Software controls scanner motion, obtains data and transfer it into computer in the form of three-dimension digital data cube. Software is capable to store 3D acoustical image of fingerprints and visually represent it in the form of C-Scan, B-Scan and A-Scan.

DEDICATION

To my Family and Brother

ACKNOWLEDGEMENTS

I thank my supervisor, Prof. Roman Maev during the development of the idea in the thesis and made many helpful suggestions. His support, encouragement and his innovative idea lead me to successfully complete this research project.

I would also like to give my sincere thanks to Dr. Fedar Severin, his selfless teaching and broad knowledge help me in learning research and guided me to the right path for this project.

Finally, I would like to give my thanks to the all committee members and research group, especially Waldo Perez who guided me in the right direction for the software development.

TABLE OF CONTENTS

DECLARATION OF ORIGINALITY	iii
ABSTRACT.....	iv
DEDICATION.....	v
ACKNOWLEDGEMENTS.....	vi
LIST OF FIGURES	viii
CHAPTER	
I. INTRODUCTION	
What is Biomtrics?	1
Biometrics History.....	2
Types of Biometrics.....	3
Advantages of Fingerprint Indentification.....	6
II. REVIEW OF LITERATURE	
Ink and Paper Method.....	9
Standard Optical Method.....	11
Optical Touchless Method.....	13
Other Techniques.....	15
Ultrasonic 2D method.....	18
III. METHODOLOGY OF 3D ULTRASONIC FINGERPRINT IMAGING.....	25
IV. PROTOTYPE OF FINGERPRINT IMAGING SYSTEM	
Cylindrical Scanner.....	31
Hardware System	32
Software System	38
V. DATA ACQUISITION.....	44
VI. CONCLUSIONS AND RECOMMENDATIONS.....	49
REFERENCES.....	51
VITA AUCTORIS	54

LIST OF FIGURES

Figure 1: Fingerprint recognition	3
Figure 2: Hand shape recognition	4
Figure 3: Anatomy of Iris visible in optical image	5
Figure 4: New Biometrics Sensor at ATM to create digital map of Blood vessels	6
Figure 5: Finger print ridges and valleys	10
Figure 6: Frustrated total internal reflection principle	11
Figure 7: In-light depression method principle	12
Figure 8: Multispectral Image principal	13
Figure 9: Transmission and reflection based Touchless finger Imaging	14
Figure 10: Information and images by TBS Holding AG, Switzerland	15
Figure 11: Capacitance Imaging Principle	15
Figure 12: Principle of thermal Imaging	16
Figure 13: Electric field method	17
Figure 14: Reflection detection	20
Figure 15: UltraTouch model 203 by ultrascan	22
Figure 16: ScanUltra Series 500 by Jaypeetex	22
Figure 17: Diagram for holographic imager	23
Figure 18: Prototype of holographic imager	24
Figure 19: Acoustical Image finger setup	25
Figure 20: Finger scanning with microscope	26
Figure 21: A-Scan, B-Scan and C-Scan	27

Figure 22: 3D Data Collection and representation	28
Figure 23: Comparison of C-Scan and ink and paper	28
Figure 24: C-Scan gate setting at sweat pores	30
Figure 25: Principle of cylindrical scanning	31
Figure 26: Fast Scanning fingerprint imaging system	32
Figure 27: Fingerprint Acquisition System	33
Figure 28: Electronic part of fingerprint prototype device	34
Figure 29: High frequency transducer	34
Figure 30: Frame SilverPak 17C	35
Figure 31: Data Acquisition Board	36
Figure 32: Optical Encoder	37
Figure 33: Software System	38
Figure 34: Software Display	39
Figure 35: Results	44
Figure 36: A-Scan	45
Figure 37: B-Scan and its component	46
Figure 38: C-Scans at the time delay 0.48 mks, 0.46 mks and 0.41 mks	47
Figure 39: Combined C-Scan after processing	48

CHAPTER I

INTRODUCTION

What is Biometrics?

Biometrics is process of obtaining, processing, and recognition of measurable biological characteristic of individual. In most cases purpose of biometrics applications is person identification in order to maintain restricted access to area or information. Application of Biometrics is rapidly evolving; they are being currently deployed and used at different location to enhance the security. The major places where it is being currently used are Intelligence Agencies (FBI), US Department of Homeland Security, Borders, Airports, Nuclear Reactors and many restricted areas of medical emergencies.

A number of existence techniques have been developed. Most popular are; fingerprints, palm print, hand geometry, iris, face, vascular pattern, and speech recognition. Existing Biometrics methods have different hardware, software, security and performance cost associated with it. In general biometrics system includes sensor, signal processing unit, storing devices and matching algorithm.

In modern Biometric systems individual characteristic is obtained by specific sensors. The sensors acquire data in analog form which immediately converted into digital representation by the analog to digital converter circuitry (ADC). The sensor plays critical role in the system and overall system performance highly depend on type and the characteristics of these sensors. Further, noise filtering and signal processing enhances the signal quality obtained by the sensor. Finally, data will be converted into standard form, checked against existing database and stored for analysis.

Amongst all these sophisticated methods, fingerprint recognition is being widely used and accepted due to the simplicity, user friendly nature and mostly – due to existence of huge databases collected by security agencies.

This project is intended to introduce a newer development in the ultrasonic fingerprint imaging. The system has the following characteristic: It produces acoustic image of fingerprint in the form of 3D data array. It uses multitransducer fast-scanning ultrasonic devices with cylindrical area of scanning to obtain data containing not only surface grooves pattern, but also information about internal structure of the fingertip (including sweat pores). If this system will be implemented successfully, it will essentially increase security and confidence by the usage of additional measure of identification. Further development may bring detection of blood movement which will allow differentiating between live finger of individual and all kind of replicas.

Biometrics History

The idea of automated Biometrics was not implemented until significant advancement in the field of computer processing. One of the oldest Biometric methods is face recognition, In the past well trained human officers were in charge of identifying individuals by recognizing face. However, due to the population growth and emerging industrial revolution in 18th century this simple task became sometimes extremely complicated. The attempts of fingerprints using for person identification started in mid-19th century. Later on 1897 first practical fingerprint classification system was developed by Inspector General of Police Bengal India Edward Henry [28]. This system allows fast sorting and matching of prints and quickly was adopted by police departments around the world. The automatic fingerprints identification was developed in 1990 due to

advancement in computer processor and programming language. The huge collections of fingerprints were converted into digital databases and the different types of computer-oriented fingerprint scanners were created.

Types of Biometrics

Modern Finger Print Recognition includes ink and paper, optical, capacitance, ultrasonic and other methods. The main problem here is obtaining of good quality fingerprint images, which sometimes is highly complicated by the surface contamination or damage of the finger skin. For criminal investigation FBI compares a submitted fingerprint against the database of millions of fingerprint, matching processing takes only few seconds. In some new systems all ten fingers are scanned and compared against the pre-existing database and matching is checked for all ten fingers.

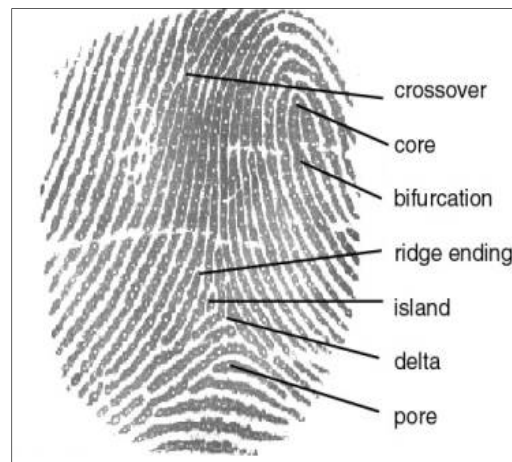

Figure 1: Fingerprint recognition [2]

Face recognition have several problems: complicated matching algorithm, influence of camera position, room lightning, weight changes and make-ups [29, 30]. Due to these problems the face recognition devices have not gain the popularity and have very limited use. The advancement in 2D and 3D imaging still keeps this method under consideration but so far there been no agreed standard algorithm for face recognition.

Hand shape recognition was able to deliver commercial biometric product. There are different problems associated with hand shape recognition, for example: Hand shape changes with the age/weight and height which on later results in false matching [31]. It also requires precise hand position; in some situation mirrors are used to take images and therefore this method is not very user friendly

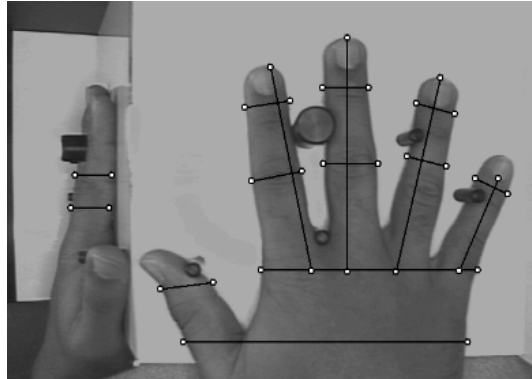

Figure 2: Hand shape recognition [3]

Another problem which limits usage of this recognition system is absence of accumulated database. That means new database has to be created which in turn require huge capital cost for installation of these systems at different places. Due to all these problems associated with this recognition system it has limited usage.

Iris recognition is one of the new and initially automated biometrics system which quickly gains popularity and currently is deployed at different places around the world. For example, this system is placed at several International airports including Dubai International airport.

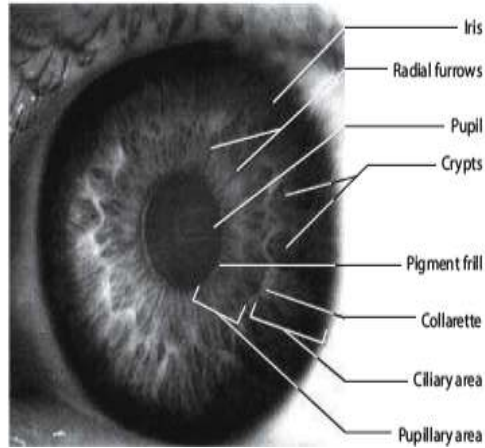

Figure 3: Anatomy of Iris visible in optical image [4]

In this biometrics system the Iris is illuminated [4] and its hi-resolution image is stored in the computer, a well-accepted algorithm is used to perform matching.

Voice recognition system is another method of recognition in which sophisticated statistical models are used to analyze the vocal system. As a disadvantage of the method, these models are highly dependable on individual health condition and characteristic of individual. Also, there is no database for this system that can be used for matching.

Vascular pattern recognition system is a new and promising biometric system which was introduced in 2000. The idea behind this technology is that blood vessels geometry of finger, hand are unique for each individual and the vascular pattern does not change with the age. The researcher claims that the blood has to flow in order to store a vascular pattern of individual.



Figure 4: New biometrics sensor at ATM to create digital map of blood vessels [5]

This technology uses infrared illumination by LED's and miniature camera to obtain and store the information about blood vessels pattern, their thickness and other parameters. A complex image processing algorithm extracts and analyzes all the information. This system is already in place at Asia and Europe, it is been currently employed at South Korea and Canadian airports.

Advantages of fingerprint identification

The only recognition system that is being used for over a century is the fingerprint recognition system. There are many reasons which offer several advantages compare to other biometrics systems. The major advantage is of course the uniqueness of each individual. Parameters, describing position and shape of the pattern features are completely unique and clearly distinguishable. The data acquisition system which traditionally includes sensor, A-to-D converter, filters and different hardware units helps in easy acquisition of fingerprint data. The clients and the users are quite satisfied with the process.

Due to the advancement in computing science the fingerprint recognition has become automatic. Each individual has several fingers with unique fingerprints which allow alternative access capabilities in case of damage or loss of one finger. FBI and Canadian Mounted Police have collected data for all ten fingerprints. Matching of ten fingers also is used to reduce the system errors when the system incorrectly matches image in the database. (The percentage measure of system incorrect matching is known as false accept rate or false match rate).

In fingerprint recognition system the scanning area is small as compare to other biometrics systems, which also means smaller identification devices. Since the fingerprint recognition is a mature biometric system, the process of fingerprint data exchange, data format, meaning and representation is standardized. This standardization is necessary because there are many different devices, sensors and algorithm in the market. The major standards which are now currently being employed in the market are fit into ANSI/INCITS 377-2004 (Finger pattern based Interchange format) and ISO/IEC 19794-2 (Finger Minutiae format for Data interchange). The further image compression is done with the help of a well-known JPEG2000 standard.

The standardization of fingerprint format is also important procedure because there are millions of fingerprint database records. The federal agencies and standardization requirements helps new acquisition devices to be compatible with already existed database.

Fingerprints also plays important role in criminalistics as the evidence left at the crime scenes. This recognition system has wide variety of civil and commercial

application. For example it helps in welfare fraud reduction, border control, driver registration, banking security etc.

CHAPTER II

REVIEW OF LITERATURE

Fingerprint image quality is one of the significant factors in biometrics system. Different technologies exist in order to acquire the image of fingerprint. In this review different technologies have been presented i.e. ink and paper method, standard optical method, optical touchless method, other techniques and ultrasonic 2D method. Ink and paper method describes its features and the process of obtaining fingerprint. Optical Touchless method explains a new approach that does not deform skin during capture of fingerprint image. Other techniques i.e. capacitance imaging, Piezo-effect imaging, thermal imaging, electric field method, OCT (optical coherence tomography) and surface acoustic impediography is presented. Finally, Ultrasonic 2D imaging describes its method and features. Literature review suggests that image obtained by ultrasonic 2D method is much better than any other method.

Ink and paper method

It is one of the oldest methods to capture fingerprint data and still it is being widely used to collect fingerprint. The process of obtaining fingerprint starts with the ridges and valleys to be covered with black ink. In the next step an impression is obtained by pressing it against the white paper. The ridge pattern is appears as the black mark whereas valleys as white. The whole fingertip area is impressed as black and white pattern on the paper. The quality of the image is highly influenced by amount of ink and the pressure applied. The advantages of this technique are simplicity, low cost and the fact that the quality of image obtained is independent of skin conditions i.e. dry, oily, and wet.

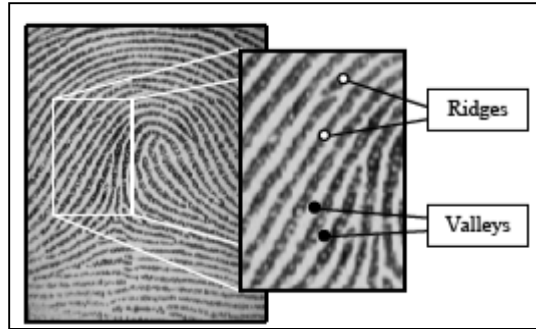

Figure 5: Finger print ridges and valleys

This technology is considered an obstacle to the new technology because a very large database is already accumulated with using of this primitive means. Any automated fingerprint technologies now have to be compatible with existing databases. This can be achieved by digitizing of paper images. The standard document scanner can convert these ink and paper impression into digital data format which can be processed and stored in computer.

This technology is still widely acceptable in many developed and underdeveloped countries because it is the cheapest method. For example Spain government uses this method to register all newborns. Spanish officers do it by applying ink at the baby's foot and then impressing it against the paper.

Although we have seen some advantage associated with this technology, it is getting obsolete due to many drawbacks. This method requires well trained personnel that should be able to take the impression correctly. The worst situation is when matching for crime scene investigation is being performed manually, because it takes very long time to identify the individual and there is a very good chance of error.

As mentioned earlier, the quality of image is highly influenced by the amount of pressure applied and quantity of ink applied to the skin. Any variation in either of these

two factors will produce a distortion on ridges and valleys of fingerprint. The attendant as well as user has to be careful about this fact.

This procedure requires cleaning of finger after obtaining the fingerprint which is an additional inconvenience to the end users. It is also subject to the health concerns because many individuals have to press against the same wet ink pad which can carry illness and diseases.

Standard Optical Method

The sensors which use light to differentiate between ridges and valleys are being employed for many years. Out of many optical methods the most common work on the principle of frustrated total internal reflection (FTIR). A transparent prism, light source and CCD or CMOS image sensor is used in this method.

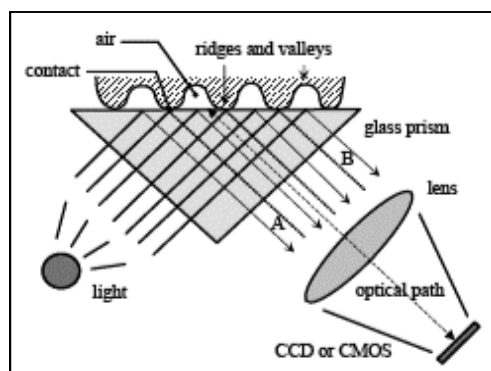

Figure 6: Frustrated total internal reflection principle

The principle of frustrated total internal reflection (FTIR) can be illustrated with the Figure 6. As can be seen that finger touches one of the surface of the prism, Light from a source enters from left side of the prism and reflects from first surface. The reflection conditions are distorted and light is scattered at the points where skin ridges are touching prism. Upon exit from the prism the light is received by the CCD or CMOS sensor where it appears black and white for ridges and valleys respectively.

The image obtained with this technology has limitations of the skin conditions; the quality of the image is highly influenced when the skin is dry or wet. When the skin is too wet there is a very little contrast between the ridges and valleys and the entire image appears to be black. The reason is accumulation of sweat in the skin valleys, light scattering in the valley portion in the same way as on ridges. This absorption produces a uniform black on the resultant image. On the other hand if the skin is dry, the ridges do not come in good contact with the prism hence will not produce contrast to valleys. The solution to dry or wet skin is gel or oil is given to the end-user to clean hands before scanning.

The oil, gel or any other substances sometimes make the situation worse because the image itself becomes contaminated with these substances and as a result the quality of image is severely affected. The efficiency of compression and other JPEG200 algorithms is also reduced. The other problem associated with this system is its size; it cannot be reduced due to limitation of optical sensor and the light path which is another drawback for these systems. The principle of interior light depression method [8, 9] is shown in figure 7. In this method light penetrate the fingers from two sources and the image is obtained directly on the optical sensor chip.

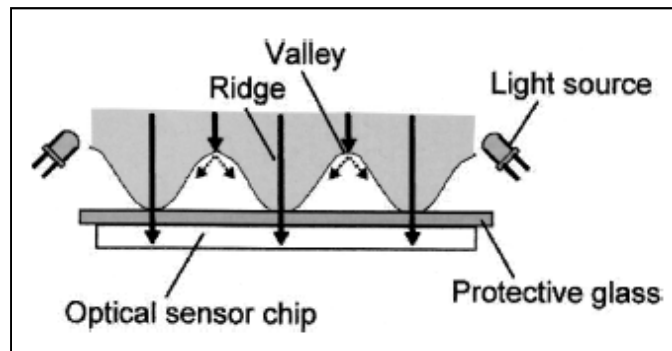

Figure 7: In-light depression method principle

Ridges which are in direct contact with the optical sensor chip allow the light to be received and appear as the bright portion of the image. Contrary to this, light trying to pass through the valleys diffuses and as a result these areas appear to be the dark portion on the image. The protective glass between optical sensor and skin helps the light to efficiently pass through the skin.

In order to improve the ridges appearance, the multispectral Image principal is used. The illustration of this method is shown on figure 8. This technique uses lights from multiple sources penetrating through the finger. After reflection from the finger this light is received

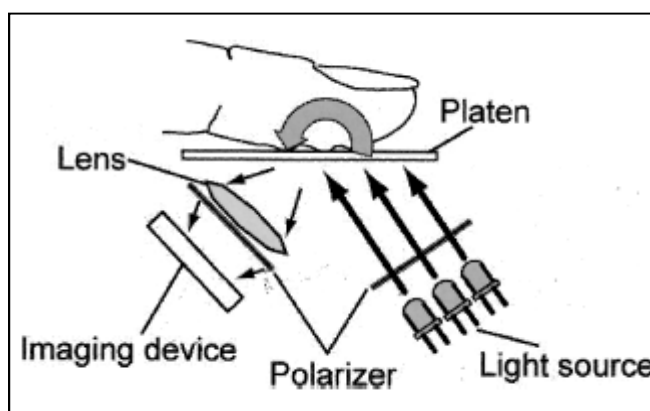

Figure 8: Multispectral Image principal

by the imaging device. Light from various sources has different wavelength, and the resulting image is produced by superposition of images in different colors. This method claims of detecting fake images when substances are present on fingerprint skin.

Optical Touchless Method

Acquisition of fingerprint is considered the most critical problem in automated fingerprint acquisition and it affects overall performance of the system.

When the fingerprint is pressed over a plane surface of standard optical sensors the skin deforms. There are different problems associated with that deformation. For example; each user applies a different pressure in different direction. The captured image suffers with noise and distortion due to irregular 3D objects on 2D flat surfaces. These problems are irreducible, random and occur during each acquisition. Due to all the problems stated existing methods show degrading overall system performance and consequently limit the spread of biometric technology. A new solution [10] was introduced in order to overcome the problem.

This new methods can be divided in two sub-groups i.e. Reflection - based Touchless Finger Imaging (RTFI) and Transmission - based Touchless Finger Imaging (TTFI). The principle of these two approaches is shown in the figure below:

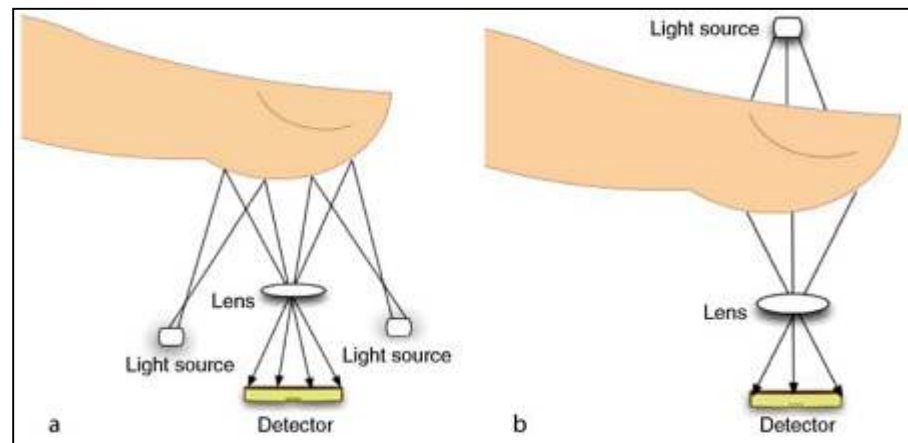

Figure 9: Transmission and reflection based Touchless finger imaging [7]

In the RTFI the light is reflected from the finger and image is obtained on the detector, whereas in case of TTFI light penetrates through the finger and is received by the detector. A lens is used in order to align the incoming light to the detector. The final image obtained have low contrast due to the fact that detector receives the reflected light from ridges as z FTIR devices. The FTIR devices use a 3D image of ridges and valleys to

generate a 2D pattern. On the other hand both types of Touchless devices can not differentiate between 2D and 3D objects. Hence just presenting a simple photograph instead real finger will attack the system. Beside this, Touchless devices produce a good quality image, faster and easier capture of fingerprint, nail-to-nail fingerprints, highly accurate, hygienic and non-intrusive for the end users.



Figure 10: Information and images by TBS Holding AG, Switzerland

Other Techniques

The capacitance imaging principle is shown in figure 11.

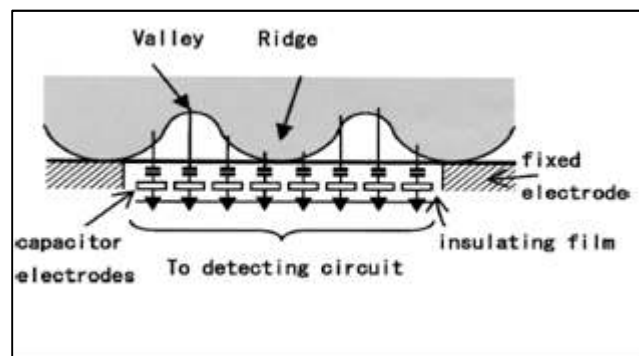

Figure 11: Capacitance Imaging Principle

The air gap between the detecting sensors and fingers act as capacitor. Image is obtained by electric charge distribution on the sensor electrodes. The contrast in the image is caused by different capacitance value for each sensor element.

In another method called Piezo-effect imaging, pressure Piezo sensors used to image the fingerprint. These sensors produce electric signal when mechanical force is applied. Magnitude of produced current depends on applied pressure; ridges and valleys generate different pressure because they are at different distance from the imaging sensor. However, in some cases this imaging device is not sensitive enough to differentiate between ridges and valleys. This device also suffers from another problem, it provides little information about the image pattern because it obtains the image in binary formation.

The principle of thermal imaging is shown in the figure 12. Sensor for this method consists of a heated semiconductor plate and the fingerprint is directly pressed over the heated surface of the semiconductor.

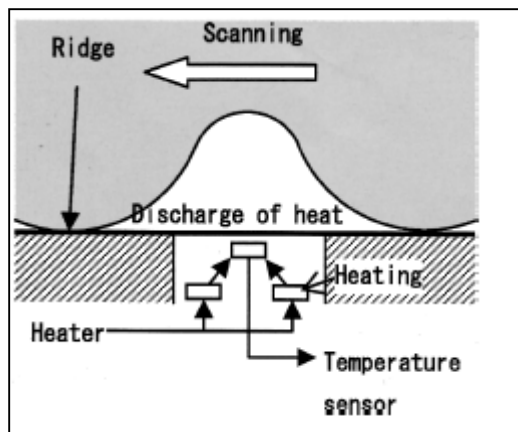

Figure 12: Principle of thermal Imaging

The portion of the finger where ridges touch the preheated surface absorbs heat from the surface and the temperature of the plate locally drops. Valleys of the finger do not come in contact with the heated semiconductor, so the surface under valleys does not lose heat. The variation of temperature is recorded and a fingerprint image is produced.

In the electric field method, an RF sinusoidal signal passes through the volume of the finger to a receiver small antenna. The output signal is spatially modulated by the subsurface of the finger.

skin. The received signal is amplified and digitized in order to produce the fingerprint image.

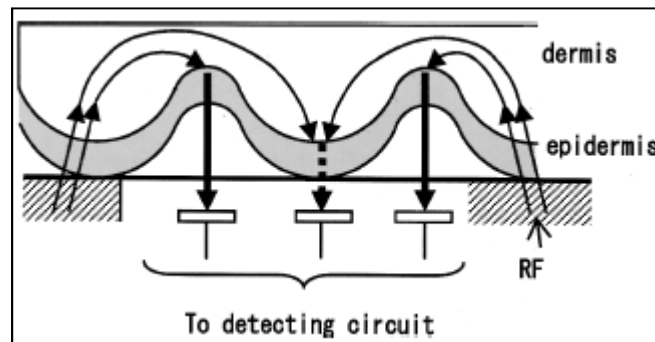

Figure 13: Electric field method

OCT (Optical coherence tomography) is novel imaging technology that can to obtain 3D images of fingerprint including in-depth layers. The OCT was presented in [13]; it is able to provide high resolution cross section of the object. This technology has attracted many researchers and was successfully deployed in the field of medical applications. The biometrics system using this method is robust against spoofing [14] and could differentiate live and dead finger by measuring blood flux. This technology is free from all distortion-causing effects. The downside of the device is its cost which is almost \$35000.00.

Surface Acoustic impediography is relatively new method for fingerprint imaging, developed only at laboratory prototype level. Piezo-elements are arranged in the form of two dimensional arrays which is capable of generating ultrasonic pulses. These Piezo-elements interact with finger pressed against the sensor surface. The portion of the fingerprint ridges which are in contact with sensor produces a different damping of oscillating elements than the valleys. The damping differential produces an image when contact occurs.

From all the discussed technologies OCT is the only method which provide the surface topology of the fingerprint but this advantage comes with the cost. All other techniques require pressing the finger against the flat surface this pressure causes stress on the finger and change the geometry of ridges.

Ultrasonic 2D method

Ultrasonic systems existing for many decades and was being under discussion since the World War II. The medical ultrasonic scanners are being used for many years and effectively working in obstetrics, cardiology, gastroenterology, urology etc. They are widely employed in medical community because there is no toxic or any other reaction to this method.

Ultrasonic images are usually obtained by computer reconstruction from spatial distribution of ultrasonic waves reflected from the object. Ultrasonic waves are defined as waves with frequency higher than upper limit of human hearing. The human is able to hear sound in the range of frequencies 20Hz – 20 kHz, so waves over 20 kHz counted as ultrasound. Most suitable for medical imaging ultrasound waves located in the range from 1 MHz up to 15 MHz

Ultrasound is the new technology for the fingerprint recognition and there are very few companies in the market who are developing these biometrics ultrasonic systems. Two-dimensional imaging of contact area with horizontal ultrasonic transducer was proposed by two companies: Ultra-scan Corporation, USA and Jaypeetex Engineering Pvt. Limited, India. Beside this, 2+-D Imaging of the contact area with ultrasonic holography technique is proposed by Optel Limited Poland. The newer technique that is based on 3D imaging of the fingerprint is proposed by Centre of

Imaging research and advance material characteristic (CIRMAC) Canada [21, 22] in late 2006 and G.Narayanasamy, University of Michigan in Ann Arbor, MI, USA [23] in early 2007.

In ultrasonic 2-D method a finger is pressed onto the flat surface of polystyrene plate and focused ultrasonic transducer scans under the plate. The ultrasonic pulse is reflected from the interface between the plate and finger and received by the same transducer. An image is produced due to the difference of acoustic impedances. Characteristic acoustic impedance of the material is defined as the product of sound velocity C_0 in the material and its density P_0 .

$$Z = P_0 C_0$$

The amount of energy transferred from one medium into another medium depends upon the acoustic impedances of both media Z_1 and Z_2 respectively. The difference in Z is known as impedance mismatch and the amount of reflected energy is proportional to the impedance mismatch. The amount of energy transmitted back to the transducer from interface of medium 1 and medium 2 is characterized by reflection coefficient, calculated as:

$$R = (Z_2 - Z_1)^2 / (Z_2 + Z_1)^2$$

In the attenuation absence total input energy equals energy reflected and transmitted so therefore transmission coefficient is calculated by subtracting reflection coefficients from one:

$$T = 1 - R$$

The ultrasonic image can be formed by mapping amplitude of wave reflected from particular area under consideration. Most often amplitude is represented by grey scale, but pseudo colors also can be used for stressing out image details.

Figure 14 shows the detailed description of the concept. Ultrasonic wave is being reflected by the reflector at distance D from the transducer at time t_0 . The velocity of ultrasonic wave in the medium is C_0 . The reflected wave is received by the same transducer. The time taken by the ultrasonic wave to travel and reflected back is given as:

$$T = 2D/C_0$$

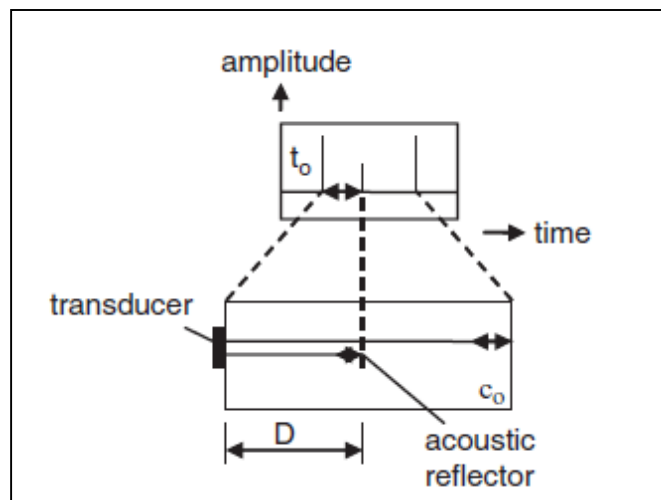

Figure 14: Reflection detection

The factor of two appears due to the reason of round trip distance of ultrasonic wave. The ultrasonic velocity is different in different medium; it is relatively low in the gas medium and high in solid mediums. The sound velocity in the soft tissues of human body is close to velocity in water and approximately equal to 1500 m/s. The adjustable electronic gates in receiving system can select signals from particular depth of the object.

The obtained data can be represented in different formats. The three most common formats are A-Scan, B-Scan and C-Scan presentation. Each of the representation

of data provides the different view of the object. Modern computer software and hardware are capable of providing all the three views of the object.

In order to obtain a good contrast image the reflection coefficient must vary significantly from ridges to valleys [19]. For making the scanning process stable the finger to be imaged is generally placed against some solid surface. Polystyrene is the best choice for material for this platen surface because it has low attenuation and its acoustic impedance better than other solids matches with the human body. The acoustic impedance of polystyrene is:

$$Z_{pol} = 249 * 10^3 \text{ (g/cm}^2 \text{ - sec)}$$

On the ridges we have polystyrene/skin interface. Acoustic impedance of tissue

$$Z_{ridge} = 155 * 10^3 \text{ (g/cm}^2 \text{ - sec)}$$

In the valley region polystyrene plate contacts with the air and the second media here

$$Z_{val} = 34 \text{ (g/cm}^2 \text{ - sec)}$$

That difference in second media gives difference in reflection coefficients from ridges and valleys [19]:

$$R_{val} = 99.7\%$$

$$R_{ridges} = 23.2\%$$

Which clearly shows ultrasonic energy is reflected back at significant amount from the valleys portion of the fingerprint. On the other hand the ridges portion of the fingerprint has absorbed energy and only 23% of the total energy is reflected back.



Figure 15: UltraTouch model 203 by ultrascan

Figure 15 shows the device designed by ultra-touch Corporation, whereas Figure 16 shows similar device developed by Jaypeetex Pvt. Limited India. Series 500 has optional scan size which is available under the software control; it has two options: express scan and full scan. Each scan has different image resolution and its usability depends upon the application where it is being employed.

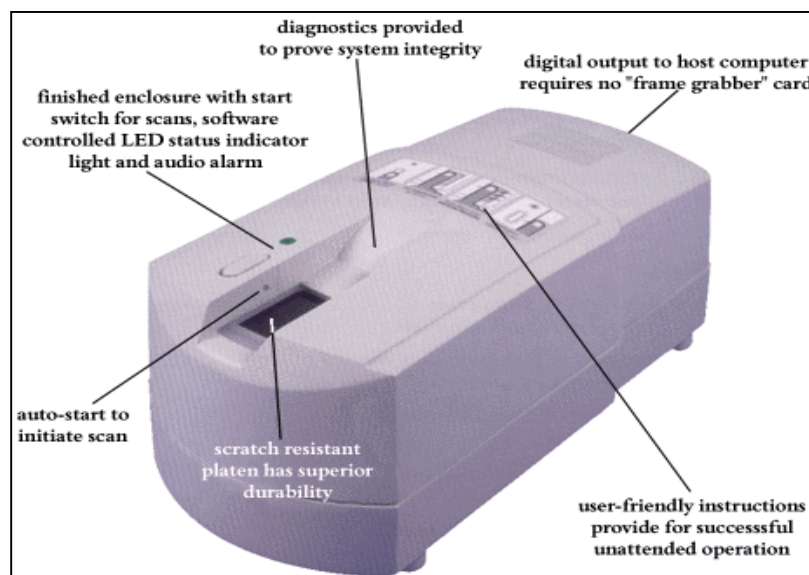

Figure 16: ScanUltra Series 500 by Jaypeetex

Ultrasonic 2D method offer several advantages over optical imaging. The current available ultrasonic readers are able to scan the fingerprint with effective area of approximately 1.5×3 cm or (0.8×1.2 ""). These devices produce high quality 2D fingerprint images with resolution up-to 500 dots per inch (dpi), 500 dpi is currently considered enough for matching purposes and storing in the computer memory. Device can read the fingerprint within range of 2-5 seconds depending upon the require resolution. This option to change resolution is incorporated in the software in order to target different industrial applications. The ultra-scan is able to scan the two adjacent fingerprints at the same time without the inclusion of extra-cost; this kind of scanning is used for high security applications.

The Ultrasonic holographic imager developed by Optel Limited Poland uses so called ultrasonic 2+-D method (Figure 17). According to this technology acoustic transducer is moving in circular trajectory around the axis of the system. It sends acoustic wave toward the plate with pressed finger and receives the scattered signal. Then, advance computer tomography is used to reconstruct the images with the resolution 0.1 mm.

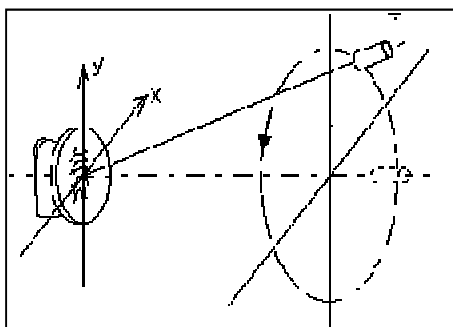

Figure 17: Diagram for holographic imager

Ultrasonic hardware works in different environment condition and unaffected by brightness or darkness in the room. The manufacturing company claims that the quality

of images produced by ultrasonic 2-D devices is far better than that of any other sensors available in the market. The matching accuracy against the database is statistically far better than other devices.

However, there are some disadvantages associated with 2-D ultrasonic devices. This method provides no information about in depth structures of finger i.e. sweat pores which are located along the ridges of the fingerprint. The plane-scanning technique limits size of scanned area.



Figure 18: Prototype of holographic imager

CHAPTER III

METHODOLOGY OF 3D ULTRASONIC FINGERPRINT IMAGING

Ultrasonic 3-D method of fingerprint imaging was proposed by [21-23]. The newer method of fingerprint imaging was introduced by [21-22] with focus on the internal structure of the fingerprints including sweat pores. The resultant image has a resolution of 500 dpi and acoustic data can be stored in the form of 3D cube.

The experimental set up for obtaining acoustic image of the finger is shown in the figure 19. Tessonics AM – 1103 scanning acoustic microscope working in short-pulse reflection mode was used to acquire the acoustical 3D data.

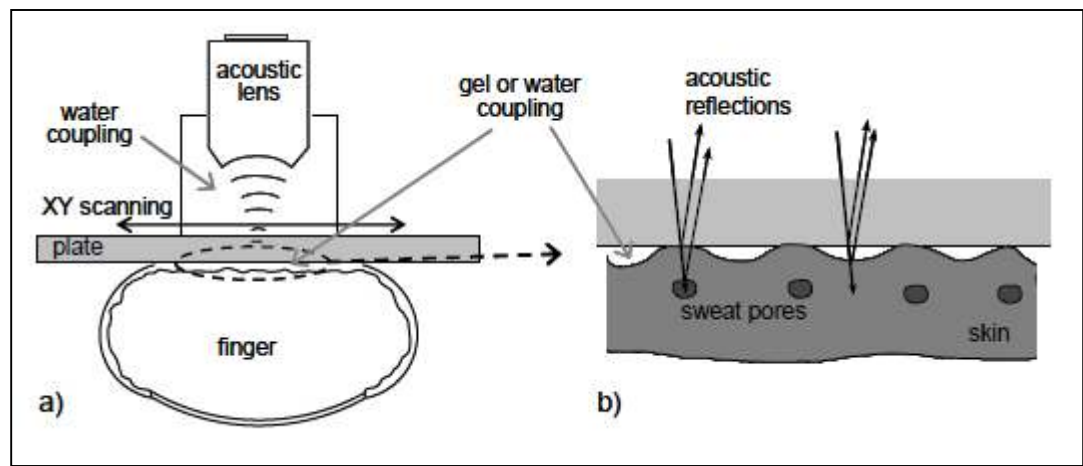

a) Finger setup under acoustical microscope b) fingerprint internal structure

Figure 19: Acoustical Image finger setup

Finger was pressed against the polystyrene plate; Acoustic gel is used as coupling between the finger and polystyrene plate. The whole assembly is submerged in water and scanned with spherically focussed acoustic lens is scans the desired area. During the scanning process a special arrangement was made to keep the finger of volunteer stationary and focus ultrasonic transducer in near sub-skin area. The optimal working frequency of the acoustic lens was determined from experiments in different frequency

ranges. It was determined that the 50 MHz works best for the acoustic imaging of the fingerprints. The time taken to acquire the image depends upon the resolution settings, it took 2-3 minutes to acquire 1000 dpi image. During scanning process for this experiment finger of the volunteer should be stationary.



Figure 20: Finger scanning with microscope

As a result of point-by-point scanning, different types of image may be formed by ultrasonic system. By convention, these images are usually called *A-scans*, *B-scans*, and *C-Scans*. Figure 21 shows graphically how the acoustic wave is converted into these various formats. The acoustic beam generated by the transducer reflect off the top surface of the sample, interfaces inside, and the bottom surface of the sample. Each of these can be displayed as pulses on an oscillogram or A-scan image. As the lens moves along a line, it collects a set of A-scan data at each point. By assigning the amplitude of each point in the A-scan data a greyscale value (e.g. peaks are lighter, valleys are darker), a B-scan image shows the shape of objects in cross-section, the location of the interfaces. As the lens scans along a set of lines, it collects a two-dimensional array of A-scan data sets

3D volume. By gating the region around the corresponding pulse in the A-scan data and assigning a greyscale value to that region based on its amplitude, a C-scan is formed. The C-scan image shows cross section in a plane parallel to the surface of sample.

For the fingerprint experiments A-scan starts a few microseconds before reflected pulse from the bottom surface of polystyrene plate and has duration 1 us, which corresponds approximately 0.4-0.8 mm depth inside the skin. A-Scans obtained during lens motion along one line of scanning were compiled into two-dimensional image B-Scan, Several B-Scans were compiled into the 3D Data cube, and horizontal slice of this 3D Data at chosen depth is the C-Scan. (Figure 22)

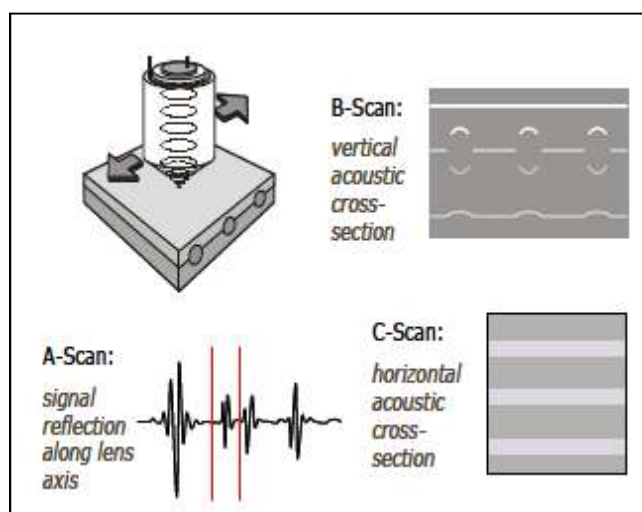

Figure 21: A-Scan, B-Scan and C-Scan

By varying position of the gate one can visualize the reflection from any chosen depth. In order to get acoustic fingerprint image the gate should be positioned on ridges and valleys of the fingerprint.

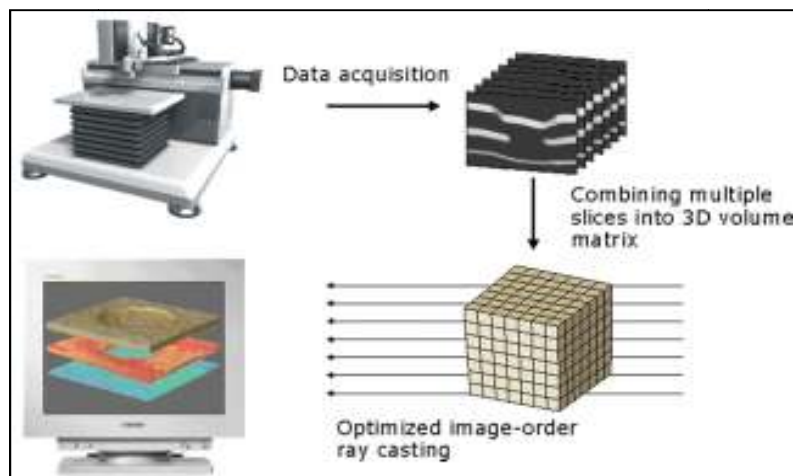

Figure 22: 3D Data Collection and representation

The resulting acoustical image is shown on the figure 23 (left side). The grooves pattern on the C-scan obviously repeats ink-and-paper image (right). The images are inverted: ridges appear as light regions on C-scan and dark on paper print. It can be fixed with logic not or invert operation of image processing, after which C-scan can be sent directly to the matching procedure.

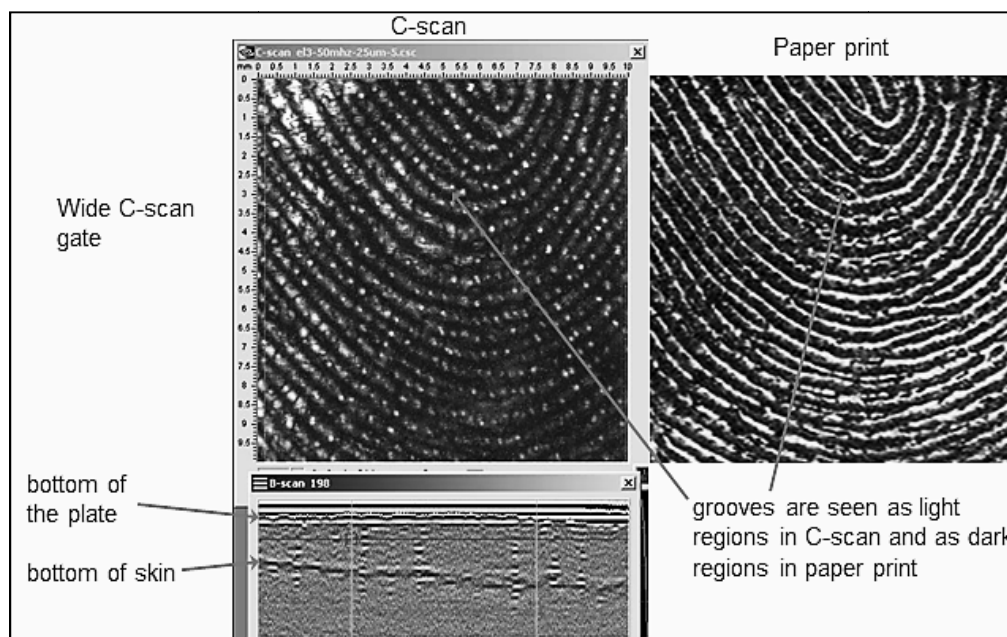

Figure 23: Comparison of C-Scan and ink and paper

This fact clearly demonstrates the applicability of the acoustic microscopy for biometrics purpose even on that first level. However, ultrasonic image contains more information. Some additional details can be seen on C-scan. First, it is rows of white spots on the ridges. It is known from the literature, that these spots are sweat pores. They should be visible even in case of damaged skin surface and can be used for fingerprint pattern restoration when ridges itself are not recognisable, second is fine net of black curves crossing the ridge. This net should represent some internal structures in the skin and potentially can be accounted in the matching process. The B-scan shown below carries information about depth-dependant distribution of the sweat pores and total thickness of the skin. All these additional elements increase uniqueness off the fingerprint and can be included into matching process. It will greatly increase security of the system.

The attention can be concentrated on those additional details only. For example, Figure 24 shows C-scan with the gate position under skin surface. Ridges are not visible here, and only sweat pores still represent their pattern. That means ultrasonic method is not sensitive to surface and its condition. Presence of liquids, dirt, paint or total absence of ridges due to abrasive exposure will not affect fingerprints reading. It's a great advantage of the method which significantly increases its robustness and protects against spoofing attack. The sweat pores are present inside the skin and are not affected by any changes accidental or internal of the finger surface.

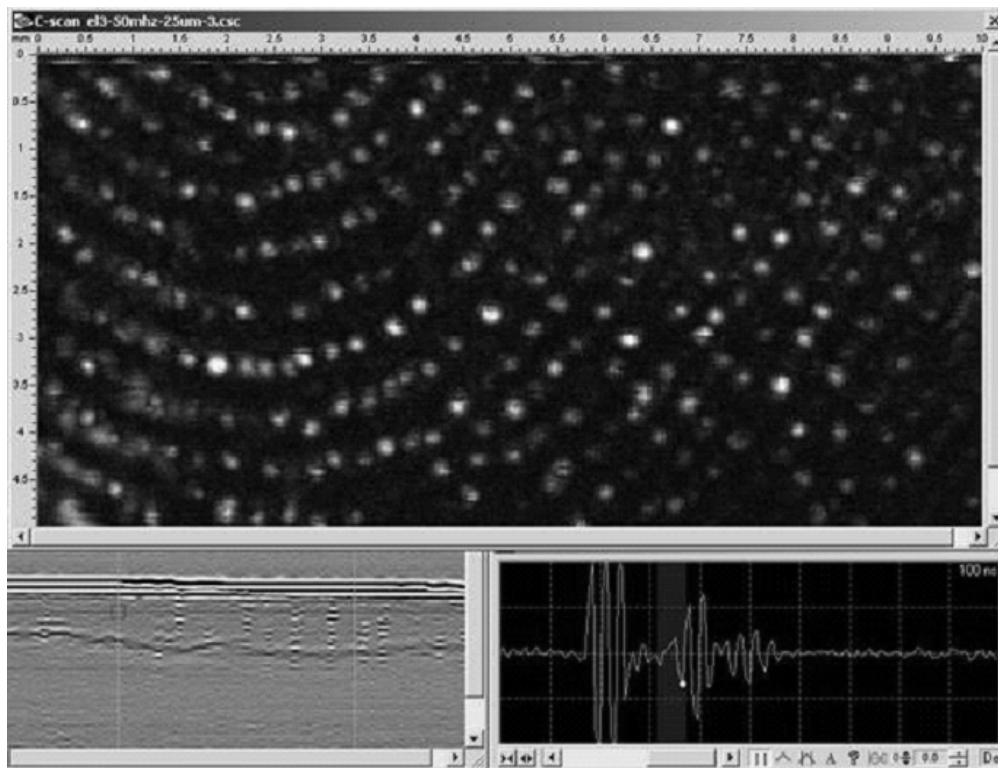

Figure 24: C-Scan gate setting at sweat pores

CHAPTER IV

PROTOTYPE OF FINGERPRINT IMAGING SYSTEM

The practical realization of 3D ultrasonic fingerprint imaging principles should be done by building a real device. Such prototype was developed and assembled in the University of Windsor. The goal of this project is to prove conception, find optimal design and configuration of device, to achieve required resolution and speed and to test overall usability and limitations.

Cylindrical scanner

One of the requirements to future system was maximal increasing of the obtained fingerprint area by including side part of the fingertip. The natural shape of human finger as a roughly cylindrical rod brought the idea of cylindrical scanner when acoustical lens rotates around the finger and linearly moves along its axis. Such spiral motion can cover the entire necessary surface (Figure 25).

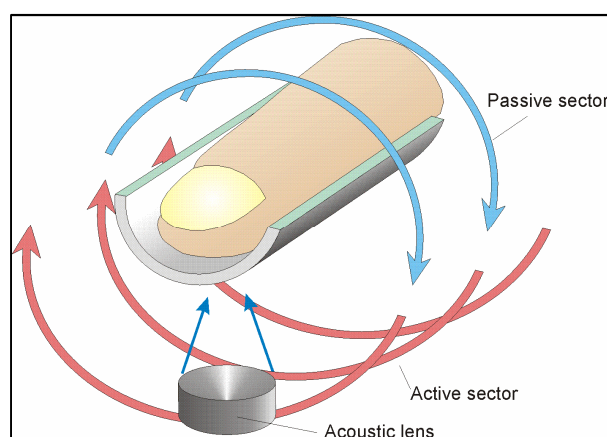

Figure 25: Principle of cylindrical scanning

Nail area should be eliminated from scanning on this stage of work, so half of its turn lens will be inactive. To reduce total scanning time, this idle period can be

compensated by operation of second acoustical lens on the opposite side of the rotor. The scanning speed can be increased further by parallel data acquisition from several pairs of the acoustic lenses. This geometry also eliminates linear acceleration and deceleration of the acoustical lens during scanning and keeps speed all the time optimal for data flow. Drawbacks of this design are necessity of electronic coupler for data transmission from the rotor to stationary electronics and necessity of multiplexer to switch the lenses. Figure 26 shows the schematics of the device.

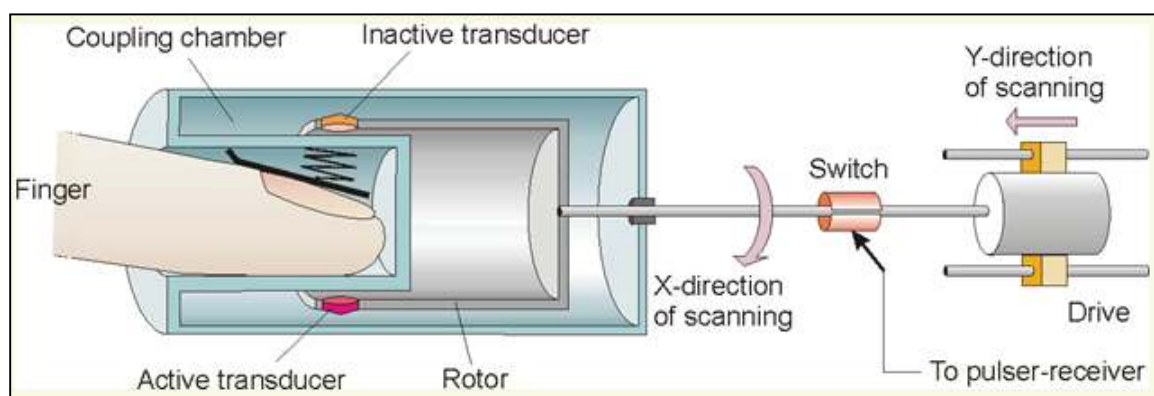

Figure 26: Fast Scanning fingerprint imaging system

The system is designed to provide fast scanning. As can be seen from schematic a finger is inserted into hollow cylinder of the scanner and pressed against concave surface of the cylinder. Set of focused ultrasonic transducer mounted on the rotor scans over the cylinder. The sound pulses pass through coupling liquid, cylinder wall and reflect back from the finger. Focal point should be located right under the skin surface and cylinder provides support for the finger to keep it unmovable during the scan.

Hardware System

These principles were realized in the laboratory prototype of the device. It was assembled mostly from standard parts available on the market to have possibility to

adjust and quickly modify the design. There was no requirement of compact size at this stage of development.

Two pairs of identical transducers were mounted on the rotor driven by the stepper motor. There were used immersion spherically focussed high resolution acoustical lenses with central frequency 50 MHz and focal distance 12 mm made by OLYMPUS Parametric NDT. Electric signal from transducers passes through inductive four-channel rotor-stator coupler to the relay multiplexer which sequentially connects them to the Pulser-receiver. The position of the rotor is determined by the incremental optical encoder. Counter circuitry transforms encoder output into controlling signals for multiplexer and triggering pulse for ADC board.

The rotor with drive, coupler, encoder and multiplexer is mounted on the linear stage which provide axial motion of the scanner. The ball screw-driven stage is powered by the second stepper motor. All the components including two power supplies, ADC board and interface connectors incorporated into rigid frame.

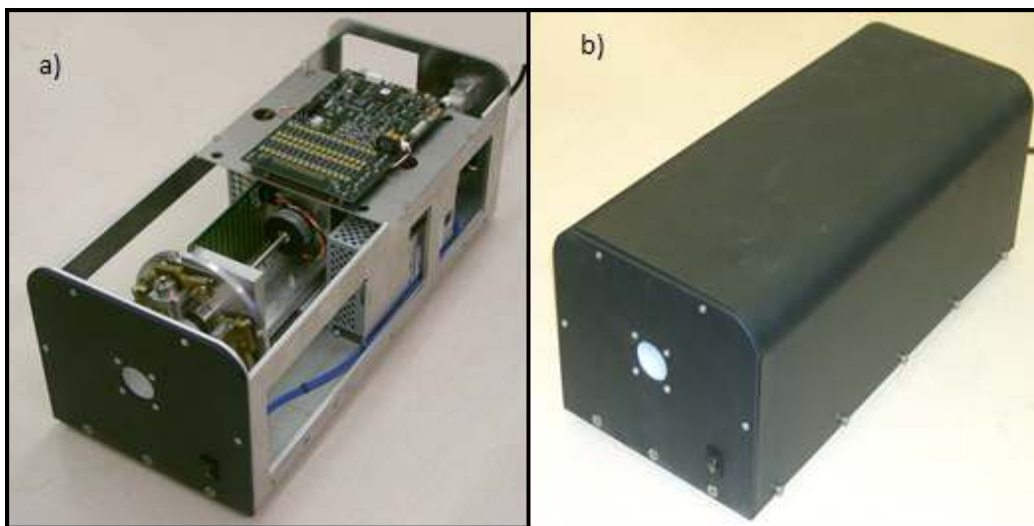

Figure 27: Fingerprint Acquisition System a) Open box b) Close box

The Block diagram of fingerprint prototype device is shown in Figure 28. The figure shows different parts of the hardware and links between them.

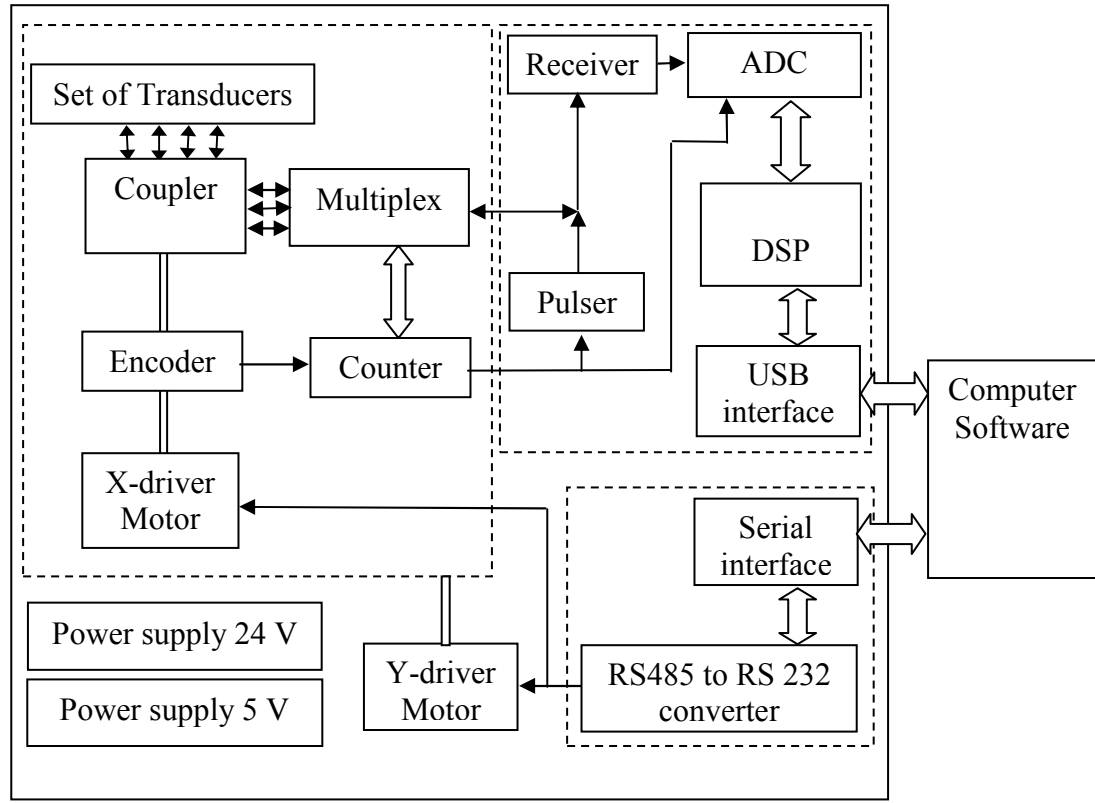

Figure 28: Electronic part of fingerprint prototype device



Figure 29: High Frequency Transducer

Two stepper motors employed in the device provides two-dimensional XY scanning. First motor provide rotation of transducer set what means fast scanning along one direction (X-direction) whereas second motor provides linear axial motion of the rotor assembly (Y-direction).

Both motors are SILVERPAK 17 C integrated motor-controllers manufactured by Lin Engineering [27] (Figure 30). They are powered by DC voltage of 12-40V, 0.2-2 Amps, serially controlled through RS485 interface and have four input/output lines. SILVERPAK 17C programmable in terms of percentage of maximum current, holding current and micro step resolution of (2x, 4x, 8x, 16x, 32x, 64x, 128x, 256x)and able to operate in standalone mode without connection to computer.



Figure 30: Frame SilverPak 17C

The full step of the motor is 1.8° (200 steps/rev). With microstepping up to 256x that means resolution up to 0.0035° or 51200 positions per turn. That gives possibility to obtain B- and C- scans in “start-stop” regime with resolution up to 1 mm. The goal is, however, scanning “on the fly”, without motion stopping.

The SilverPak designer kit also includes RS485 to RS232 converter card, which was used for direct connection with computer. Since most of modern office computers doesn't have RS232 port anymore, standard USB-to-serial adapter was emulating this port. One port can control up to 16 SilverPak motor-controllers.

The data acquisition board, designed by Tessonics Inc. is shown in figure 31, is responsible for acquiring data, processing data and sending it to the computer software. This board based on ADSP Processor 2181KST-133 (Analog Devices).

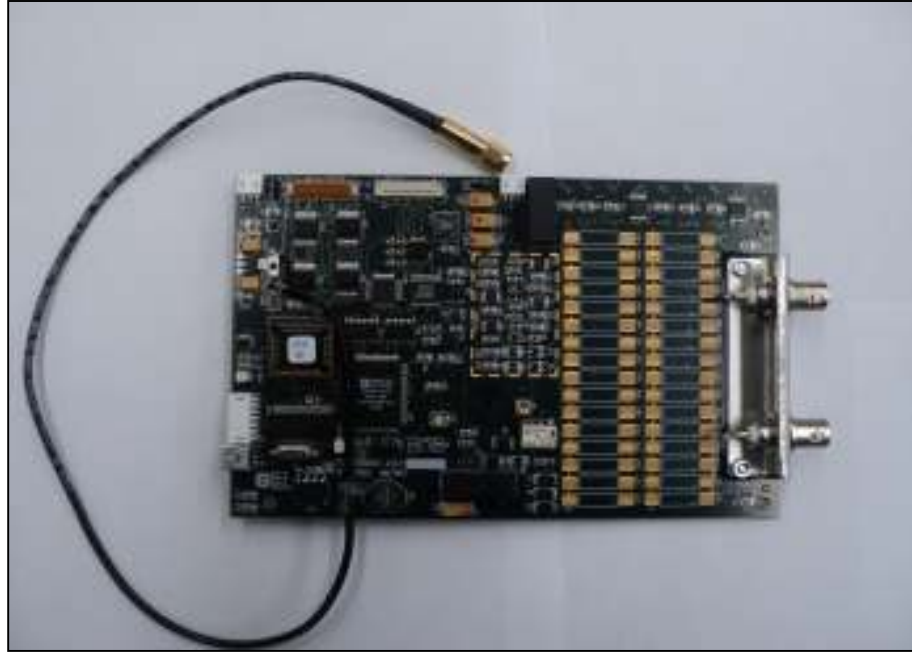

Figure 31: Data Acquisition Board

The main feature of this processor is Instruction cycle Time starts from 20 MHz, 80K Bytes of On-chip RAM, Independent ALU and Multiplier/accumulator. The board has also build-in memory for the data storage purpose. The memory can store each A-Scan as well as the whole B-Scan; these settings options are available in the software.

The build-in Pulser sends high voltage spike to transducer for excitation of ultrasound pulse. After the reflection from the skin signal passes through receiver-amplifier in analog form. It has to be converted in to digital format in order to store and process in the computer. The ADC824E converter on the board performs the analog to digital conversion. It has a sampling frequency up to 66 MHz, but with software super

sampling operation effective sampling rate may be increased up to 528 MHz, Resolution of ADC converter is 8-bit, which is enough for Ultrasonic Imaging of fingerprints.

Another board in the hardware incorporates counter circuitry and multiplexer. It takes signal from optical encoder and provide trigger to Pulser and ADC board to synchronize A-Scan with position of the rotor. The incremental optical encoder (Figure 32) provides output in form of two square wave signals and home position pulse. It has resolution 2500 points per revolution.



Figure 32: Optical Encoder

During rotation counter forms trigger pulse corresponding to each front of encoder signals, i.e. 2500 pulses per turn. The A-scan acquisition starts on each pulse. The inner diameter of support cylinder was chosen 24 mm, so its circumference $24 \times 3.14 = 75.4$ mm. As result, hardware-determined spatial resolution of the system in the X-direction is: $75.7 \text{ mm} / 2500 = 0.03 \text{ mm}$ or 850 dpi.

The counter divides encoder sequence with coefficient 625, i.e. its output gives 4 pulses per revolution. These pulses are used for multiplexer control. Each acoustical lens connected to Pulser-receiver for one quarter of turn. As result, the scanning sector and

point of each A-scan in output B-scan is hardware-bounded to position of the rotor and independent from rotation speed. Second axis of the scanner (Y- direction) is controlled independently from the software. The velocity of linear motion in this direction was chosen to provide the same resolution 0.03 mm between B-scans.

Two power supplies are installed to supply DC power to the system. One power supply is delivering 24 Volt; it is being utilized by two SILVERPAK 17C motors. The other power supply is delivering 5 Volts; this power is being used by electronic circuitry i.e. data acquisition board, and multiplexer board.

Software Systems

The software system is designed in Delphi 2009; Delphi offers several features which include graphical user interface, pointers and lots of freely available online libraries. The main reason for using the Delphi language in this system is existence and availability of Delphi-based DLL for the hardware board that is being designed by Tessonics Inc. The Software system itself is consists of number subparts or files. The software system diagram is shown in Figure 33.

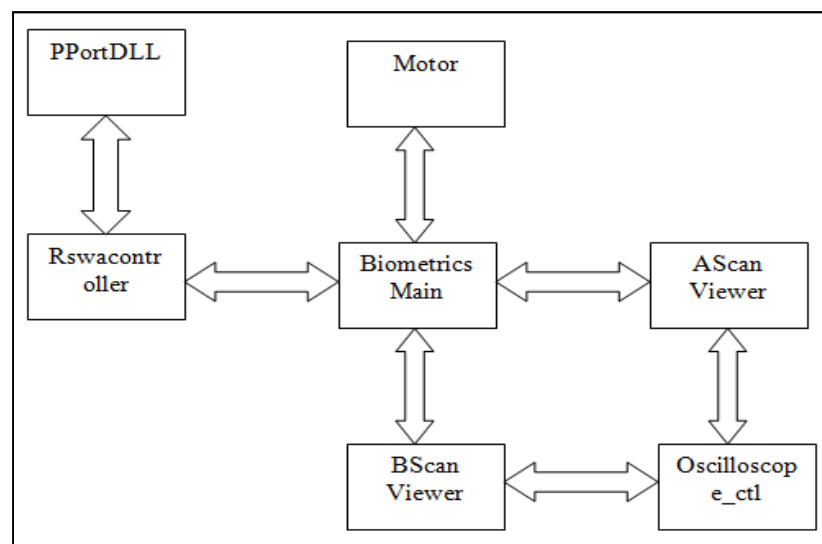

Figure 33: Software System

The main components of the software are: BiometricsMain, PPortDLL, Rswacontroller, AScanViewer, BScanViewer and Oscilloscope_ctl. BiometricsMain class is the central class of the software which interacts with almost all others.

The program starts with number of initializations. The data acquisition board requires initialization for setting the communication mode which is set to the USB mode. The other initializations performed are: setting the parameters of A-Scan i.e. sample size, sampling rate and delay. Motor Initialization is also performed, it establishes communication between motor and serial port, and will set the initial position of the motor.

BiometricsMain class creates the 3D Data and stored data in 3D array; 3D data is created by combining all the B-Scan. The speed of the system is currently 100 A-Scan per second, which means that Data acquisition can deliver up-to 100 samples per second via USB communication.

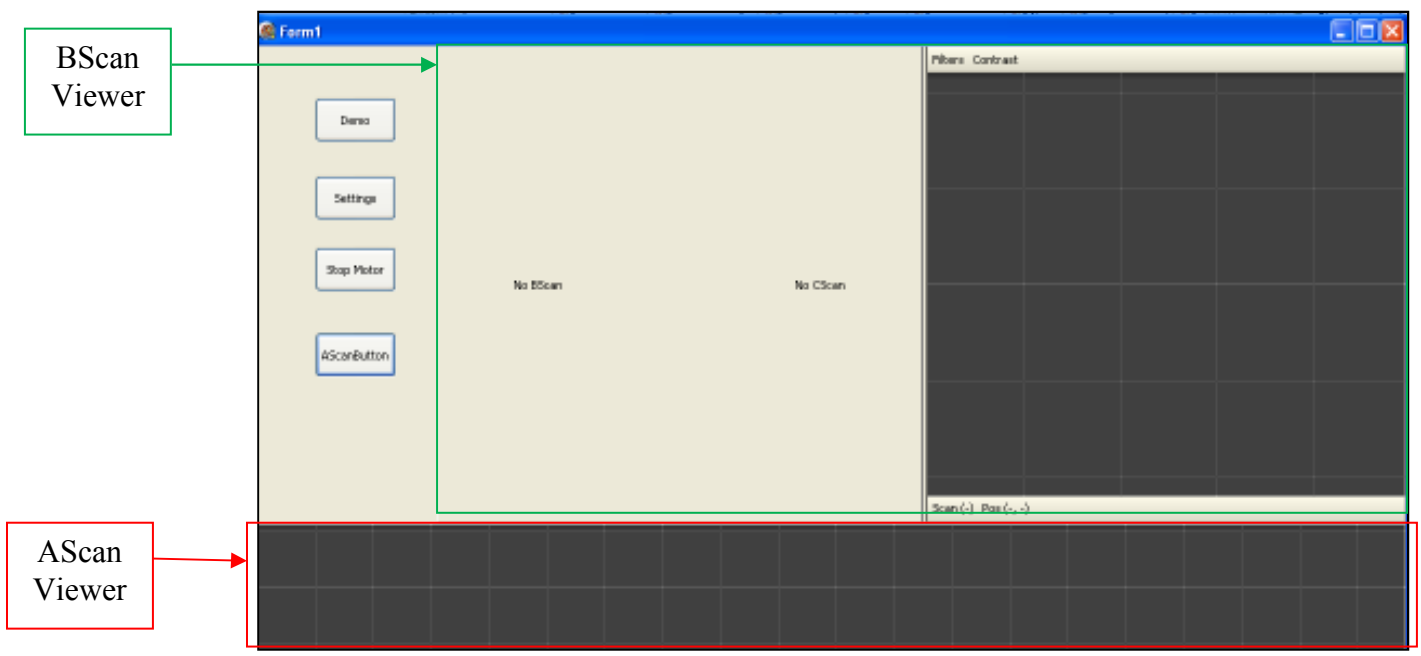

Figure 34: Software Display

BScanViewer displays B-Scan and C-Scan of fingerprints. This class creates bitmaps for displaying images, several procedures and functions work together in order to produce the resultant image. 3D Data which was acquired by BiometricsMain transfers to BScanViewer for displaying on the screen. UpdateBitmap and UpdateBitmapCScan procedures update the bitmap when the newer 3D data is received by BScanViewer unit. Upon user click on particular cross section on the C-Scan on the BiometricsMain display area, SetActiveAScan and SetActiveBScan procedures update the image. This class helps for recreating B-Scan and A-Scan from any point. This feature gives total control over the visualization and representation of acquired data..

AScanViewer class inherits from Oscilloscope_ctl which means it has all the functionalities and properties of Oscilloscope_ctl. The public procedures which can be accessed by BiometricsMain or any other class are Create, Clear, AddAScan, SetSelection and Set Message. Create constructor is accessed by BiometricsMain; this constructor overrides the Oscilloscope_ctl class control constructor. BiometricsMain assigns panel (area) to this constructor where A-Scan has to be displayed.

AddAScan procedure is a public procedure and it is accessed by BiometricsMain, AddAScan requires two arguments in its arguments list Adata and Acolor. Adata is of type Single Dynamic array which is the AScan data acquired during the scanning process. Other argument in AddAScan is AColor which is type cardinal, it is the color of AScan data which has to be displayed on BiometricsMain GUI. Private procedures in AScanViewer Class i.e. Drawcontent, DrawOverlay and Gethittest are overriding the Oscilloscope_ctl class procedure and providing drawings for the displaying purpose.

Motor class is responsible for communicating through the serial port with SILVERPAK 17C motor. This class includes the libraries and uses CPort and CPortCtl. All WinAPI is written in these classes which are lower level communicating commands with serial port. These libraries for Delphi are free available on the internet, they also include all general purpose procedure required to communication with the motor serial port. Unit Motor has class TMOTORControl, it has private and public procedure. Public procedures which are accessed by BiometricsMain are motorConnect,, SetMotorDemoParam, moveMotorDemo, StopMotor, motorDisconnect and SetPortSetting.

motorConenct procedure opens the serial port for communication procedure, After opening the serial port is ready to accept data. SetPortSettings sets different communication parameters required for communication purpose i.e. port number, baud rate, data bits, stop bits, parity and flow control. For communication with SILVERPAK17 C these parameters values should be set up as “COM3”, 9600, eight, one bit, none and none correspondingly. On clicking on the settings button of the BiometricsMain form these parameters pop up as a window and user can change these parameters.

ClearMotorCommands procedure clears all the commands if present in SILVERPAK 17C motor. WriteStr(‘/ATR + #13#10’) method will clear all the commands from both motors (‘/ATR + #13#10’). This command is an example of DT Protocol which allow unit to be commanded over a simple serial port. Explanation of command syntax is given below:

Start Character	Address	Commands	Run	End of string
/	1-9*	Command strings	R	<CR>

The start character “/” has to be used in every command to the motor, it advises the serial port about start of command. The address determines which motor number to take the appropriate action. The commands strings tell what exactly motor expected to do. The list of commands is provided in documentation and on manufacturer website. For example command P10000 ask the motor 1000 steps in positive direction. The positive or negative direction of motor can be set by another command. Run command (syntax R is short cut for Run) can be seen in (‘/ATR + #13#10’). End of string command tells the serial port that the command has ended. A Delphi and visual Basic use (#13#10) for command end for communicating with serial port, this combination is also known as carriage return. Address of each motor in the system should be set manually by dial switch located on the motor. In the command (‘/ATR + #13#10’) ‘A’ will clear everything on the address 1 and 2.

SetmotorInitialPosition and setMotorInitialspeed will move the motor to the initial positions and setup its speed before start of scanning. A sleeping time 50ms between setting the position/speed of motor1 and 2 is important because motor takes about 50ms to react to a command. There should always be sleep time between commands during communicating with the serial port of the motor.

Rswacontroller and PPortDLL are used to communicate with the data acquisition board. Rswacontroller is wrapper for PPortDLL; it is wrapping the functions, variables from PPortDLL. PPortDLL contains initialization mode flags, communication parameters

flags, scanning mode flags, status return codes of hardware, Errors in function parameters, hardware error return codes and multiplexer flags. Structures TConfigParam, TScanParams are declared here, they are used by functions as pointers to initialize the hardware and communication parameters.

TConfigParams structure parameter is passed as buffer pointer to the function setConfigParams in the function parameters list. It is used for enabling scanners, pulser receiver and BScan parameters, BScan parameters are initialized when whole B-Scan should be stored in the memory.

TScanParams sets the A-Scan parameters before beginning of scanning. It defines the pass size which is the no. of samples in received signal, gain of the amplifier and Passdelay determine delay between trigger pulse and start of acquisition of the received signal. Different Initialization functions and Scanning function are available such as GetAScan, GetBScan and SetCommsParams. GetAScan function gets the AScan and store the result in single dynamic array. Function SetcommsParams set the communication parameters. Implementation of these function are hidden in PPortDLL.dll file, it directly communicate with the hardware.

Since we need some of the functionalities and flags of PPORTDLL, we need a wrapper. Rswacontroller unit wraps those functions and flags. Rswacontroller calls initialization and scanning function and brings the data to BiometricsMain; BiometricsMain in turn passes the data to displaying classes AScanViewer and BScanViewer.

CHAPTER V

DATA ACQUISITION

The created software for fingerprint imaging is able to control motors, ADC board, store data and represent them in form of A-Scan, B-Scan and C-Scan. When software starts, window of Graphical User Interface appears on the screen First it initializes the system; make connection with motors, set communication parameters for the serial port, set communication parameters for the data acquisition board and set scanning parameters. By clicking on the AScanButton software start acquisition.

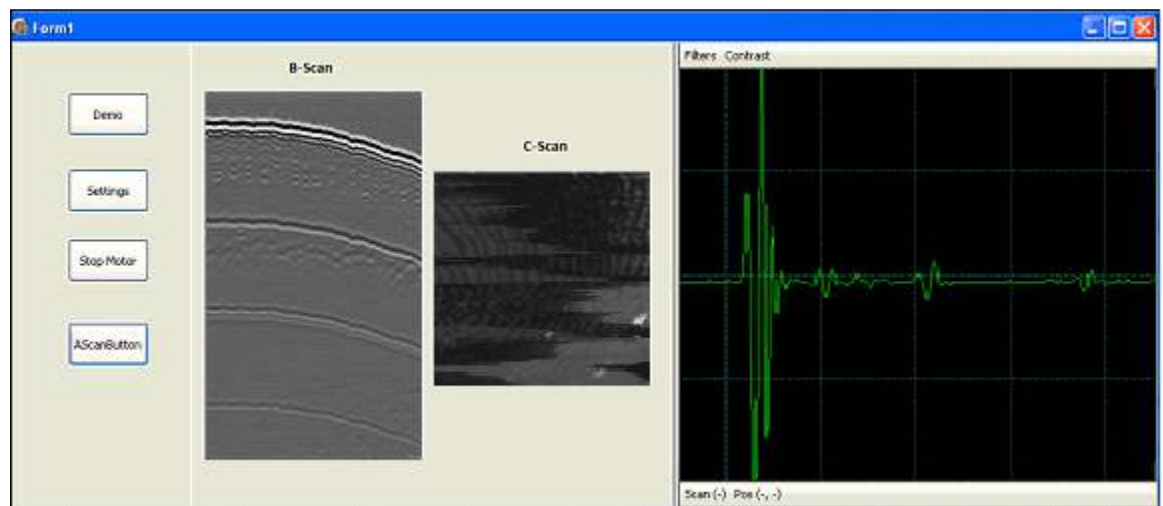

Figure 35: Results

Y-direction motor moves linear stage into initial position, X-direction motor start rotation, and when its reach operational velocity scanning with data acquisition starts and system begins gathering data and stores as 3D matrix. The results represented on the screen shown in Figure 35, it shows A-Scan, B-Scan and C-Scan. C-Scan shows the fingerprint image, whereas B-Scan demonstrates one of the cross-sections of the finger skin. By clicking on the C-Scan operator can obtain B-Scan in that particular cross

section of data volume. Similarly, by clicking on particular point of B-Scan the corresponding A-Scan can be seen as waveform.

Below is represented one particular set of 3D data collected with the following parameters: central frequency of lens 50 MHz, Sampling rate is 512 MHz, 3D volume 200 x 200 x 1000 pixels. It represents area of fingertip 11 mm x 11 mm. Total volume of the data is around 27 MB. The time taken by the device to produce an image will depend from require resolution. Currently it took 2 minutes to acquire full volume 3D Data. This limit is imposed by transferring sequence of A-Scan data to the computer through USB communication. Optimization of this procedure will reduce scanning time.

This 3D volume consists from matrix of A-scans, similar to one shown in Figure 36. Here first large pulse 1 corresponds to reflection from inner surface of support cylinder, other visible pulses represents sound bouncing between transducer and outer surface of base cylinder. The reflection from the skin, small noise-like pulses 2 located right behind first pulse.

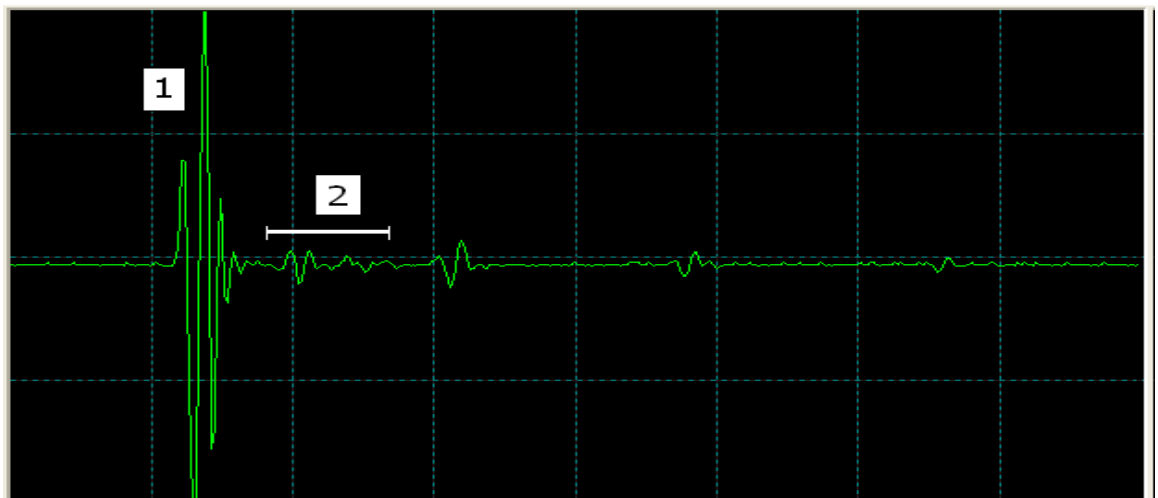

Figure 36: A-Scan

The example of B-scans taken during rotational motion is shown in Figure 37. The upper bright line is representing surface where finger contacts with polystyrene support cylinder. Ideally this line should be straight and horizontal, but due to mechanical imperfections of the scanner it looks this way. The axes of rotor and support cylinder are not completely coinciding, so distance between lens and surface changes across the scanning line and this affects B-scan.

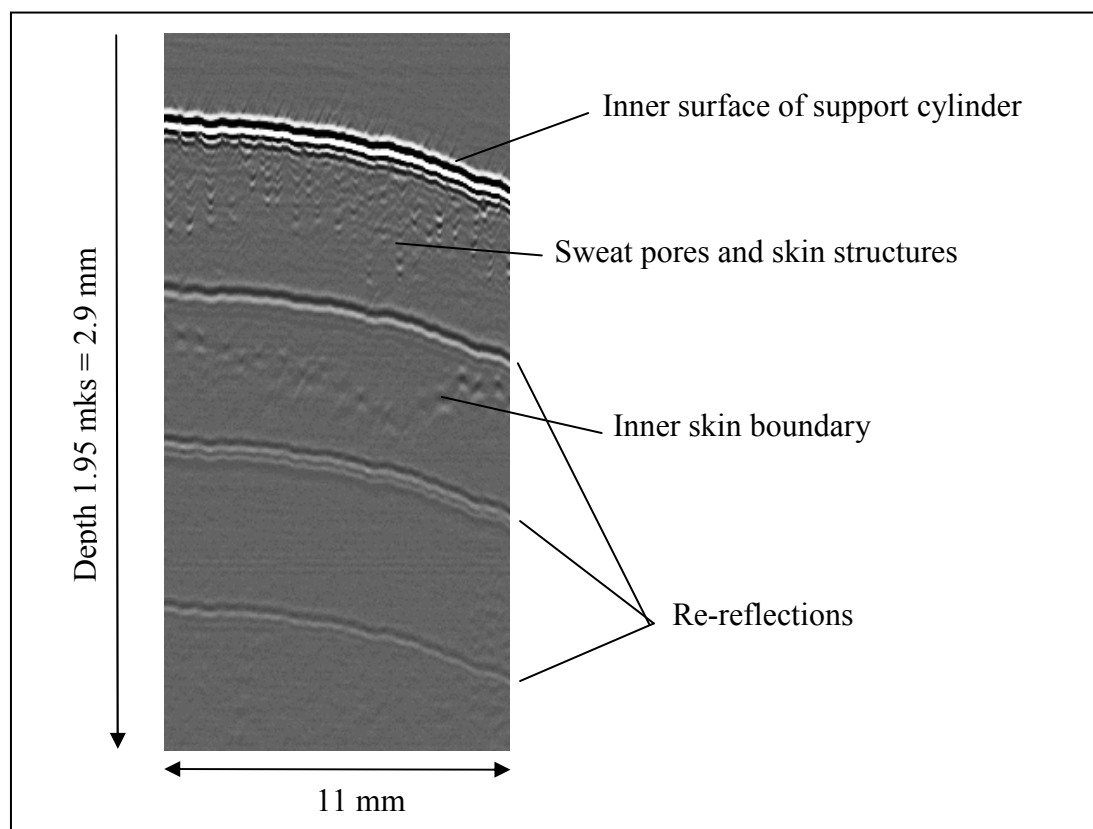

Figure 37: B-Scan and its component

The sweat pores and other skin structures located behind surface line and they are clearly visible. Also back boundary of the skin is well recognizable. The thickness of skin varies in range 0.8 – 1 mm along the B-scan line. Three solid lines spaced by the same distance from surface and following its shape are not represents any feature of skin – they appear due to ultrasound bouncing between acoustical lens and support cylinder. These

lines may be eliminated in different scanner design or subtracted from signal during image processing.

By varying position of C-scan gate reflection from appropriate depth can be seen. Three C-scans at the different depth are shown on Figure 38. The fingerprint pattern is visible, ridges and valleys can be clearly distinguished. The different areas of C-scans have different brightness because of mentioned above scanner imperfection and mechanical shaking. The mounting of support cylinder was not robust enough, distance between lenses and cylinder was not consistent between B-scans. As result, different parts of the signal entered C-scan gate during scanning.

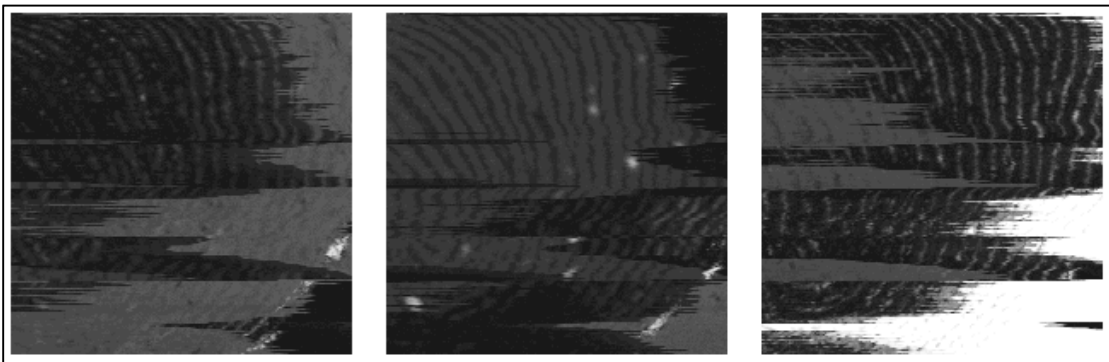

Figure 38: C-Scans at the time delay 0.48 mks, 0.46 mks and 0.41 mks

The manual shifting of the B-scans (done afterwards in Matlab) produces combined C-scan free from these defects (Figure 39). In the future, that shifting may be done automatically and be incorporated into data processing part of software. This image is suitable for identification purposes. Future development of the system including increasing of mechanical rigidity and improving of signal-to-noise ratio of receiver will provide images with better quality.

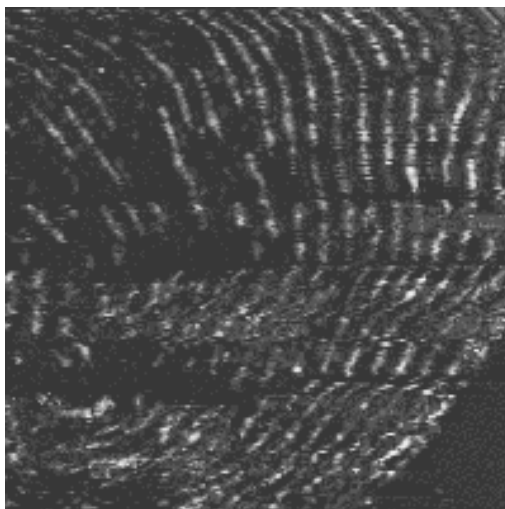

Figure 39: Combined C-Scan after processing

CHAPTER VI

CONCLUSIONS AND RECOMMENDATIONS

The goal of this research is development of ultrasonic system for 3D imaging of the fingerprint. The method uses 50 MHz pulse-echo ultrasonic system in combination with mechanical cylindrical scanner. Obtained 3D cube of data is stored in computer memory and available for processing and representation. The acoustic images of the fingerprint show high contrast between valleys and ridges and are comparable with the ink-paper method.

Internal structure of the fingerprint i.e. sweat pores also have imaged. It can be used as an additional security feature because they cannot be altered by surgery. There is no sensitivity to contamination of the finger surface. C-scan images are similar to paper prints and can be linked to existing databases.

The conception of the device was proven by building hardware and software prototype. Its testing provided information for the improvement. As the next step scanner should be readjusted and its rigidity should be increased in order to reduce mechanical shaking and image distortion. The amplitude of exciting pulse should be increased and additional electromagnetic shielding should be done to increase signal to noise ratio. The software should be modified in order to optimise data transferring procedure. The current system acquires A-Scan and immediately transmits it through USB communication to the computer. Next A-scan acquisition starts right after the first one. The current time necessary to transmit one A-Scan to the computer memory is 10 ms. Instead of getting continues A-Scans the series of A-Scan should be accumulated in the Data acquisition

board memory and transmit a B-Scan as a whole to the computer. This should drastically reduce scanning time.

Graphical user interface should be improved in order to provide flexibility to control scanning parameters. Data processing module should be added with ability to compensate A-scans time shifting.

Finally all the information containing in 3D cube of data including sweat pores position and other skin structures needs further investigation. It has to be determined its uniqueness for individuals and applicability for identification purposes. This information should be combined into one resulting image suitable for matching procedures. The software can be transformed into client-server model and incorporated into identification system which includes databases and matching algorithms.

REFERENCES

1. <http://www.biometrics.gov>
2. <http://www.biometricsinfo.org/fingerprintrecognition.htm>
3. A. Ross, A. Jain, and S. Pankati, A Hand Geometry based verification system
http://biometrics.cse.msu.edu/hand_proto.html
4. J. Waymen, A. Jain, D. Maltoni, D. Maio, Biometrics Systems Technology,
Design and Performance Evaluation, Springer – London, 2005
5. W.D. Jones, Blood Test, Spectrum IEEE, 2006, p16-18.
6. D. Maltoni, D. Maio, A.K. Jain, S. Parbhakar, Handbook of fingerprint
recognition , Springer, 2003
7. S. Z. Li, A. K. Jain, Encyclopaedia of Biometrics, Springer – New York, 2009
8. S. Emiko, M. Takuji, M. Masahito, S. Masahiro, S. Koichi, O. Masato,
Masamitsu H, Fingerprint sensor based on interior optical characteristics of the
finger, Electronics and Communications in Japan, 2008, Vol. 91, No. 7, p 472-
479
9. K. Uchida, Fingerprint identification. NEC Advance Technical Journal, 2005,
Vol. 2, p19–27
10. R.K. Rowe, K.A. Nixon, S.P Corcoran, Information Assurance Workshop, Proc.
IEEE, 2005.
11. G. Parziale, Advances in Biometrics Sensors, Algorithms and Systems, chap.
Touchless Fingerprint Technology, Springer, Berlin, New York, 2008
12. www.tbsinc.com

13. D. Huang, E. Swanson, C. Lin, A. Et, Optical Coherence Tomography, Science, 1991, Vol. 254, p1178–1181.
14. A. Bossen, R. Lehmann, C. Meier, Internal Fingerprint Identification with optical Coherence tomography, IEEE Photonic Tech. Letter, 2010, Vol. 22, p507-509
15. N. K. Ratha, and Venugovindraj, Advances in Biometrics Sensors, Algorithms and Systems, Springer, 2008, p63-74.
16. <http://www.ndt-ed.org/>
17. J.K. Schneider, S.M. Gojevic, Ultrasonic imaging system for personal identification, Ultrasonic Symposium, 2001 IEEE, Atlanta, GA , USA
18. <http://www.ultra-scan.com>
19. J.K. Schneider, D. C. Wobschall, Live scan fingerprint imagery using high resolution C-scan ultrasonography, Security Technology, 1991. Proceedings 25th Annual IEEE International Carnahan Conference
20. <http://www.optel.pl>
21. A. Maeva, F. Severin, High resolution ultrasonic method for 3D fingerprint recognizable characteristics in biometric identification, Ultrasonics Symposium (IUS), 2009 IEEE International, 2009 , p2260 – 2263.
22. R.Gr. Maev, E.Y. Bakulin, E.Y. Maeva and F.M. Severin, High Resolution Ultrasonic Method for 3D Fingerprint Representation in Biometrics, Acoustical Imaging, 2009, Volume 29, Part 5, p279-285, Springer.
23. G. Narayanasamy, J. Fowlkes, O. Kripfgans, J. Jacobson, M. D. Maeseneer, R. Schmitt, P. Carson, "Ultrasound of the Fingers for Human Identification Using Biometrics" Ultrasound in Medicine and Biology Vol. 34, No. 3, p392-399, 2008

24. <http://www.jaypeetex.com/>
25. R.Gr. Maev, F. Severin and Moeen ud Din, High-resolution ultrasonic method for 3D fingerprint imaging, Ultrasonic Imaging and Tissue characterization Symposium, Arlington, Virginia, 2011
26. R.Gr. Maev, F. Severin and Moeen ud Din, High speed ultrasonic system for fingerprint imaging, International Congress on Ultrasonics, Gdansk, Poland, September 5-8, 2011
27. <http://www.linengineering.com/LinE/>
28. E.R. Henry, Classification and Uses of Fingerprints, Routledge, London, 1900.
29. W. Zhao, R. Chellappa, P. Phillips, and A. Rosenfeld, Face recognition: A literature survey, ACM Computing Surveys, 2003, Vol. 35, issue 4, p399-458.
30. W.A. Barrett, A survey of face recognition algorithms and testing results, Signals Systems and Computers, November 1997, Vol. 1, p 301-305
31. A.K. Jain, A Rose, S Parbhakar, An introduction to biometrics recognition, IEEE transaction on Circuits and Systems, January 2004, Vol. 14, p 4-20

VITA AUCTORIS

Moeen ud Din was born in Peshawar, Pakistan. He received his B.Sc. Electrical Engineering degree from University of Engineering and Technology Peshawar, Pakistan (UET Peshawar) in 2006. After graduation he worked as Lecturer at Department of Electrical Engineering at UET Peshawar. He is currently a candidate from Master of Applied Science degree at University of Windsor, Ontario, Canada.