

University of Windsor

Scholarship at UWindor

Electronic Theses and Dissertations

Theses, Dissertations, and Major Papers

1979

Aspects of carbon incorporation utilizing detritus and algae by the rotifer *Brachionus patulus*.

Kenneth H. Owen
University of Windsor

Follow this and additional works at: <https://scholar.uwindsor.ca/etd>

Recommended Citation

Owen, Kenneth H., "Aspects of carbon incorporation utilizing detritus and algae by the rotifer *Brachionus patulus*." (1979). *Electronic Theses and Dissertations*. 1215.
<https://scholar.uwindsor.ca/etd/1215>

This online database contains the full-text of PhD dissertations and Masters' theses of University of Windsor students from 1954 forward. These documents are made available for personal study and research purposes only, in accordance with the Canadian Copyright Act and the Creative Commons license—CC BY-NC-ND (Attribution, Non-Commercial, No Derivative Works). Under this license, works must always be attributed to the copyright holder (original author), cannot be used for any commercial purposes, and may not be altered. Any other use would require the permission of the copyright holder. Students may inquire about withdrawing their dissertation and/or thesis from this database. For additional inquiries, please contact the repository administrator via email (scholarship@uwindsor.ca) or by telephone at 519-253-3000ext. 3208.



National Library of Canada
Collections Development Branch

Canadian Theses on
Microfiche Service

Bibliothèque nationale du Canada
Direction du développement des collections

Service des thèses canadiennes
sur microfiche

NOTICE

The quality of this microfiche is heavily dependent upon the quality of the original thesis submitted for microfilming. Every effort has been made to ensure the highest quality of reproduction possible.

If pages are missing, contact the university which granted the degree.

Some pages may have indistinct print especially if the original pages were typed with a poor typewriter ribbon or if the university sent us a poor photocopy.

Previously copyrighted materials (journal articles, published tests, etc.) are not filmed.

Reproduction in full or in part of this film is governed by the Canadian Copyright Act, R.S.C. 1970, c. C-30. Please read the authorization forms which accompany this thesis.

**THIS DISSERTATION
HAS BEEN MICROFILMED
EXACTLY AS RECEIVED**

AVIS

La qualité de cette microfiche dépend grandement de la qualité de la thèse soumise au microfilmage. Nous avons tout fait pour assurer une qualité supérieure de reproduction.

S'il manque des pages, veuillez communiquer avec l'université qui a conféré le grade.

La qualité d'impression de certaines pages peut laisser à désirer, surtout si les pages originales ont été dactylographiées à l'aide d'un ruban usé ou si l'université nous a fait parvenir une photocopie de mauvaise qualité.

Les documents qui font déjà l'objet d'un droit d'auteur (articles de revue, examens publiés, etc.) ne sont pas microfilmés.

La reproduction, même partielle, de ce microfilm est soumise à la Loi canadienne sur le droit d'auteur, SRC 1970, c. C-30. Veuillez prendre connaissance des formules d'autorisation qui accompagnent cette thèse.

**LA THÈSE A ÉTÉ
MICROFILMÉE TELLE QUE
NOUS L'AVONS REÇUE**

ASPECTS OF CARBON INCORPORATION UTILIZING DETRITUS
AND ALGAE BY THE ROTIFER BRACHIONUS PATULUS

BY

Q KENNETH H. OWEN

A Thesis

Submitted to the Faculty of Graduate Studies through the
Department of Biology in Partial Fulfillment
of the Requirements for the Degree of
Master of Science at the
University of Windsor

Windsor, Ontario, Canada

1979

© Kenneth Herbert Owen 1979

All Rights Reserved

727766

ABSTRACT

The Intrinsic Rate of Increase of Brachionus patulus was determined using algae, aged detritus, sterile detritus and bacteria as food rations. Rotifers feeding on aged detritus were found to have survivorship not significantly different from animals fed algae but algae-fed rotifers produced more eggs and had a higher Intrinsic Rate of Increase. Heinle's (1977) theory of the absence of some trace metabolite from detrital bacteria for the unsuitability of detritus in supporting reproductive populations of zooplankters is indicated by these results.

Sterile detritus-fed rotifers reacted similarly to starved animals indicating that detrital particles have no nutritional value apart from being a substrate for the attachment and growth of bacteria and protozoans.

Incorporation rate experiments were carried out to determine whether food selection is practiced by this rotifer. Algae and detritus were mixed and the rate of incorporation of each measured. It was found that algae was incorporated at the same rate as detritus when each food type was found alone but upon mixing, the incorporation of detritus dropped significantly while algae incorporation was unaffected. The incorporation rate of detritus rose only when the concentration of algae in the food mixture was one third that of detritus.

No preference for bacteria attached to detrital particles as opposed to unattached, suspended bacteria was observed in this rotifer.

The importance of detritus to rotifers may lie in avoiding competition with larger plankters for the preferred food, phytoplankton.

ACKNOWLEDGEMENTS

I wish to express my thanks to Dr. J. Winner and Dr. D. Wallen for assistance rendered in the preparation of this thesis and in the research.

I would also like to thank Dr. M. Sanderson for her proof-reading and advice.

Special thanks are owing to my wife and parents for their moral support over the course of this project.

TABLE OF CONTENTS

ABSTRACT	iv
ACKNOWLEDGEMENTS	v
LIST OF TABLES	vii
LIST OF FIGURES	viii
INTRODUCTION	1
GENERAL METHODS	6
EXPERIMENTS	
I Intrinsic Rate of Increase	10
II Effect of Antibiotics of Incorporation Rate	22
III Selection Experiments	25
DISCUSSION	34
LITERATURE CITED	38
VITA AUCTORIS	42

LIST OF TABLES

TABLE		page
1	Medium manipulations for Intrinsic Rate of Increase Experiment	16
2	Lifetime, number of eggs female ⁻¹ and intrinsic rate of increase for <u>Brachionus patulus</u> fed various food types	18
3	The effects of antibiotics on incorporation rate of <u>Chlamydomonas</u> by <u>Brachionus patulus</u>	23
4	The incorporation rate of suspended bacteria and bacteria attached to detrital particles	27
5	Concentration of food types for selection experiments	30
6	Incorporation rate of algae and detritus in mixed suspensions	32

LIST OF FIGURES

FIGURE		page
1	Incorporation rate experiment apparatus	14
2	Death rate curves of <u>Brachionus patulus</u> fed various foods	20

INTRODUCTION

Considerable attention has been directed recently to the nature of detritus and its utilization by a large variety of aquatic animals. Many studies have elucidated the processes involved in the conversion of sloughed particulate and dissolved materials into nutritionally important substances. These processes include adsorption of dissolved and particulate matter onto substrates, leaching of plant cells, colonization of particles by bacteria and mechanical action by waves.

Sources of detrital material include phytoplankton (Golterman 1972, Rodina 1966), macrophytes such as Thalassia, Zosteria and brown algae, as well as mangroves and terrestrial plants (Fenchel 1970, Harrison and Mann 1975b, Knauer and Ayers 1977, Mann 1972, Odum and de la Cruz 1967 and Odum and Zieman 1972), feces from zooplankton and shrimp (Steele and Baird 1972 and Johannes and Satomi, 1966) and particulate matter formed by the adsorption of dissolved matter onto substrates such as bubbles and inorganic particles (Baylor et al 1962, Povoledo 1972 and Riley 1963).

The dynamics of degradation of detrital particles has been elucidated by a number of authors. Olah (1972) in studying the processes involved in Phragmites decomposition and Golterman (1972) studying similar processes in algae, describe three steps in the succession of a particle from the status of recently deceased to mature detritus. Initially, leaching of dissolved material occurs due to autolysis. Subsequently, rapid bacterial colonization of the particle occurs. This colonization period which may last from one to two weeks is characterized by a succession of bacterial populations. The decomposition process culminates in the stabilization phase where a climax population

of bacteria are found attached to the particle. Eventually, there occurs a gradual decline in the number of microbes in stabilized detritus.

Knauer and Ayers (1977) described two phases of the decomposition of detritus which correspond to the above mentioned colonization and stabilization periods. During phase I nutrients in the particle itself are utilized for bacterial growth. By phase II, the plant material remaining in the detrital particle only provides an inert attachment surface for the microbes.

This succession may be interrupted and also enhanced by grazing activity of a large number of organisms. Lopez (1977) found that Orchestia grillus ingested a microbe-particle complex, stripped the particle of its microbes then egested the particle. This particle was then recolonized, reingested and a second microbial community digested. It was also observed that grazing activity stimulated decomposition activity possibly by producing a shift in species of the microbial community.

The processes involved in producing usable food resources from detrital particles was affected by the source of the particle being acted upon. Tenore (1977) found that the red macrophytic alga Gracilaria was oxidized at a much higher rate than the eelgrass, Zostera and was incorporated by the polychaete Capitella capitata at a much higher rate in the initial stages of decomposition. However, Zostera continued to be incorporated at increasingly higher rates for a longer period until it reached its maximum where it was incorporated at a much higher rate than Gracilaria was at its maximum. This temporal separation of maximum utilization allows maximal exploitation of the available resources.

3

Although detritus has long been recognized as contributing to the nutrition of certain aquatic organisms, its significance in the role of rotifer nutrition has not been confirmed (Dumont 1977). Ruttner (1952) in discussing zooplankton nutrition, noted the importance of fine organic detritus as a substitute for nanoplankton under certain conditions. Ruttner also cited Putter's (1909) calculations that phytoplankton production, cannot, in many waters, sustain zooplankton nutritional needs, recently corroborated by Finenko and Zaika (1970) and Heinle and Flemer (1975). Saunders (1972) in addition, found phytoplankton production wanting as a sole source of energy in in situ zooplankton energy budgets. He estimated that detrital biomass exceeds that of phytoplankton by 1.3 to 16.9 times in a productive lake in Michigan and that it is necessary to consider assimilation of detritus as well as phytoplankton and suspended bacteria to obtain balanced energy budgets.

Recent studies of the role of detritus were stimulated by Odum and de la Cruz (1963) when they defined detritus as the particulate fraction of organic matter resulting from excretions or death of organisms. Wetzel et al (1972) subsequently modified this definition to include the bacteria associated with the actual particle. It is these bacteria which are often cited as the important nutritional component of detritus. Dumont (1977) feels that to make a distinction between detritus and bacterial clumps would be extremely difficult.

The nutritional value of detritus to zooplankters has been demonstrated by a number of workers. Rodina (1964) found cladocerans grew well when fed sterile detritus but failed to produce eggs. Heinle et al (1977) found a similar pattern in estuarine copepods. Nauwerk

(cited in Dumont 1977), on the basis of his study of the foods of limnetic rotifers, has concluded that bacteria and detritus are both important non-algal components of a filtrator's food.

In several studies of higher invertebrates, benthic forms especially, bacteria provided the link necessary between primary production of the littoral zone in the form of detrital particles and secondary production of animal tissue. The bacteria converted material which was indigestible to a readily assimilated form. Lopez (1977) found that Orchestia grillus digested only the bacteria associated with detritus produced from Spartina litter. Newell (1965) made similar observations studying Hydrobia ulvae, a gastropod. Adams and Angelovic (1970) found that particles which had been colonized by bacteria were more readily digested than non-colonized particles by the gastropod Bittium varium, Palaemonetes pugio, a shrimp and the polychaete Glycera dibranchiata.

Odum and de la Cruz (1963) and Nauman (cited in Dumont 1977) both made a distinction between young or fresh detritus and old detritus. Fresh detritus is thought to be more nutritionally significant by both authors for different reasons. Odum and de la Cruz suggest a decline in energy of detritus with age due to the draining of nutrients through heterotrophic succession. Nauman feels that detritus eventually becomes impregnated with iron and, because of this, is avoided by plankters.

The importance of detritus specifically to rotifers may lie in a number of competition related processes. Pennington (1942) found that Daphnia could eat 45 times as many cells of the small alga Diogenes per day as the rotifer Brachionus calyciflorus. The coexistence of these two groups of animals in nature, then, may be a result to the ability of a rotifer population to avoid competition with cladocerans and/or to

sustain themselves during periods of low algal productivity by utilizing a lower quality but more abundant food source, detritus.

There are several observations which substantiate this theory. Nauwerck (cited in Dumont 1977) found that Cladocera were associated with algal peaks, while Rotifera were associated with bacterial and subsequently detrital peaks. Dumont (1977) suggested a competitive advantage is conferred upon rotifers over cladocerans in blue-green algal blooms. A decomposer shunt is in operation in such blooms whereby resources tied up in filamentous biomass are made available through bacterial action. This bacterial action produces small particles suitable for use by filter feeders. Although both rotifers and cladocerans can utilize this material, rotifers alone can feed continuously, unhindered by algal filament blockage of the filtering apparatus.

Furthermore, the differences in assimilation efficiencies between rotifers and cladocerans suggests another non-algal resource available to rotifers (Dumont 1977). The fecal material of the relatively inefficient Cladocera probably contains resources that rotifers can utilize. Since a cladoceran's daily food ration is much larger than a rotifer's, the fecal material from one cladoceran would be sufficient to sustain numerous rotifers.

In order to elucidate the importance of detritus and bacteria to a limnetic rotifer, the following investigations were carried out. Experiments were designed to test the suitability of detritus for sustaining reproductive populations of rotifers and the relative importance of bacteria and detrital particles as components of detritus. The incorporation of detritus in the presence of varying concentrations of algae was also measured to determine if selection is practiced.

METHODS

a) Rotifer Culture

Brachionus (=Playias) patulus, a common planktonic Monogonont rotifer, was collected from a weed choked pond located at the mouth of the Thames River near Jeanettes Creek, Ontario (Canadian Topographic Map Series, Chatham 1:50,000 Sheet, Military Grid Reference 816 857). The rotifer was cultured in the laboratory under continuous indirect light in Bristol's medium with sheep manure infusion (James 1974). Chlamydomonas spp. were used as a food source. These algae, as well as the algae used in the experiments were cultured in Bristol's medium under continuous light from a 150 watt floodlight which passed through a 15 cm. water filter to dissipate excess heat. Algal cultures were shaken continuously to prevent settling.

b) Labelling Bacteria

A natural population of bacteria was labelled by adding 50 μCi of ^{14}C -protein hydrolysate (Amersham) to a medium consisting of 900 ml sterile pond water, 1 g caseitone and .1 g yeast extract. An inoculum of 100 ml non-sterile pond water was added and the culture was grown at 37°C for 48 h (Sorokin 1966).

c) Labelling Algae

Two fresh cultures of Chlamydomonas were started one week before the day of the experiments in Bristol's medium, Forty eight hours before the day of the experiment, 20 μCi of $\text{Na}_2^{14}\text{CO}_3$, pH 9.5, was added to one of the cultures.

d) Labelling Detritus

Detritus particles were produced by mascerating the macrophyte Anacharis in a Polytron homogenizer. This suspension was passed

through a .147 mm mesh seive and then autoclaved, for 15 min.

To colonize the detritus particles with a labelled bacterial population, 600 ml of ^{14}C -labelled bacteria were added to 1200 ml of unlabelled detrital suspension. This was then incubated for 2 h at 37°C (Adams and Angelovic 1970) and the unattached bacteria were separated from the detritus by centrifuging the suspension at 7000 rpm for 20 min. The resultant pellet was resuspended in 1000 ml sterile Bristol's medium.

e) Measurement of Incorporation Rate

Incorporation rates were determined using feeding chambers consisting of a 40 ml inner feeding compartment suspended in an outer chamber containing the food suspension (Figure 1) (Bennett 1977, Bevan 1977). The inner compartment was open at both ends, one being covered with a 300 μm mesh to retain the animals while allowing circulation of the food suspension. A slowly rotating magnetic stirrer prevented food particles from settling out during the feeding periods.

A large number of animals (50-75) were placed in the inner compartment and then into a chamber containing unlabelled food for a 1 h pre-graze period. During this period the animals became acclimated to the apparatus and the food type offered. Following this pregraze, the compartments containing the animals were transferred to ^{14}C -labelled food for 4 h. At the end of this graze period, the animals were returned to the unlabelled food for 1 h. This postgraze allowed the egestion or assimilation of food found in the guts of animals at the end of 4 h (Rigler 1971).

After the postgraze, the animals were filtered out on Sartorius membrane filters and rinsed with distilled water. Forceps were used

to transfer the animals to 10 ml TEG scintillation fluid to which 1 ml NCS tissue solubilizer was added. This reduced self absorption of the particles. Vials were kept at 50°C overnight then stored for 48 h to reduce chemoluminescence (Lampert 1974). Samples of the food suspensions were filtered through Sartorius membrane filters for radioactivity measurements. All radioactivity was measured on a Beckman LS 3150 liquid scintillation counter using the external standard method for quench correction.

Particulate carbon (POC) content of the food suspensions was determined by a modification of the technique of Strickland and Parsons (1968).

In the experiments using the detrital-bacterial association as the ration in which only the bacteria were labelled, the concentration of labelled particulate carbon in the bacteria was estimated using the following technique. The radioactivity of the detritus-bacteria complex was determined, as was the radioactivity and POC of the bacterial suspension which was used to produce the complex. The following values were obtained:

'W' dpm of the detrital suspension

'X' dpm of the bacterial suspension

and 'Y' $\mu\text{g C l}^{-1}$ of the bacterial suspension

$$\frac{X \text{ dpm}}{Y \mu\text{g C l}^{-1}} = Z \text{ dpm}/\mu\text{g C l}^{-1}$$

and $\frac{W \text{ dpm}}{Z \text{ dpm}/\mu\text{g C l}^{-1}} = M \mu\text{g C l}^{-1}$ of the detrital bacteria.

In this way only labelled bacterial carbon was used in the calculation of incorporation rates.

Incorporation rates were calculated using the following equation

from Bell and Ward (1970) after Sorokin (1966):

$$C_i = \frac{M}{r} \times \frac{d}{t}, \text{ where:}$$

C_i = amount of organic carbon incorporated individual⁻¹ hour⁻¹ (μg),

M = amount of organic carbon per unit volume food suspension ($\mu\text{g l}^{-1}$),

r = radioactivity of volume unit food culture (dpm l^{-1}),

d = radioactivity of the consumer at the end of the experiment
($\text{dpm individual}^{-1}$),

and t = duration of the exposure of consumers to labelled food (h).

EXPERIMENTS

I INTRINSIC RATE OF INCREASE

In this experiment the ability of 'aged' detritus and 'sterile' detritus to support reproductive populations of Brachionus patulus was investigated.

METHODS

Neonates of B. patulus used in the experiment were hatched within 12 h of each other. They were obtained by isolating a large number of cultured egg-carrying females into 'mini-culture' and after 12 h, selecting the newly hatched animals for experimental manipulation.

Detritus particles were produced as outlined in the General Methods then treated in the following manner. The fine detrital suspension was divided into two samples. Penicillin G Sodium (Ayerst) (1000 IU ml^{-1}) and Streptomycin sulphate (50 mg l^{-1}) were added to one sample (Mullin and Brooks 1967) which was then stored at 8°C . This treatment produced a detrital sample in which the bacterial populations were severely reduced in number. Hence, this sample is referred to as the 'sterile' sample.

An inoculum of 5 ml of a suspension of 'natural' detritus was added to the second sample. This was obtained from an aquarium which contained a natural assemblage of marsh pond flora, fauna and detritus collected from the pond from which the rotifers were collected. This second sample was then incubated at 30°C for 6 days and this 'aged' detritus was stored at 8°C . Colonization of the aged detritus by bacteria was obvious due to the aggregation of particles in the suspension caused by the adhesive action of bacterial polysaccharide excretions. This aggre-

gation was not observed in sterile detritus. Direct observations of the bacterial attachment to detrital particles were made using acridine orange stain and epifluorescence microscopy techniques (Francisco et al 1973). Samples of both types of detritus were stained by mixing a drop of a 1% solution of dye on a slide. These preparations were observed immediately and the attachment of bacteria to the aged detritus and the lack of attachment of living material to sterile detritus particles was confirmed. Aged particles were found to have red to orange coloured fluorescing attachments (bacteria and protozoans) while no such activity was noted on sterile detritus particles.

Intrinsic rates of increase were measured by exposing the zooplankters to five different treatments of food combinations (Table 1). Groups of thirteen or fourteen 1 ml capacity Syracuse watch glasses were filled with one of the combinations described in Table 1. A single specimen of B. patulus neonate was added to each watch glass (King 1967). These watch glasses were then placed in the dark in a sealed airtight plastic chamber containing a thin layer of water on the bottom to prevent the evaporation of the medium in the experimental vessels.

The animals were observed twice daily for the first two days then once daily for the remainder of the experiment. The hatched young and/or the aborted eggs produced during this period were counted and discarded. An experiment was terminated when all animals were dead. The medium and food were changed daily. Particulate carbon content of all food types was determined and dilutions were made to allow similar POC levels to be available in all treatments.

RESULTS

Survivorship, fecundity and intrinsic rate of increase (r) of

these zooplankters are summarized in Table 2. Mortality rate curves are seen in Figure 2. An Analysis of Variance (ANOVA) was performed on each parameter and all treatments showed significant differences among groups. Sum of Squares-Simultaneous Test Procedure (SS-STP) (Sokal and Rohlf 1969), an a posteriori test on the initial ANOVA was applied to pairs of treatments to determine differences.

The survivorship of animals fed Chlamydomonas alone (11.86 days \pm .58) was not significantly different from those fed aged detritus (9.91 days \pm .80) (SS = 17.90 $p < .05$, n.s.). The remaining pairwise comparisons were all significantly different from one another ($p < .001$ in all cases) except for the comparison of the survivorship of animals fed sterile detritus and those kept in Bristol's medium with antibiotics. No difference was detected in this case (SS = .73 $.5 < p < .75$, n.s.).

Animals fed Chlamydomonas were found to be significantly more fecund than those fed aged detritus (8.25 ± 1.0 eggs female⁻¹ compared to $1.55 \pm .46$ eggs female⁻¹, respectively) (SS = 208.3 $p < .001$). There was no significant difference in fecundity between animals fed aged detritus and those fed Chlamydomonas plus antibiotics (SS = 6.57 $p < .05$ n.s.)

Intrinsic rate of increase of animals provided Chlamydomonas as the ration ($.358 \pm .032$) differed significantly from animals feeding on aged detritus at the .005 level (SS = .39).

Rotifers were initially placed in 1 ml Bristol's medium to determine the lifetime of starved animals. However, it was observed that the Bristol's medium supported growth of airborne bacteria on its surface, resulting in a bacterial film. Animals were feeding by situating themselves vertically with their coronas in juxtaposition

to the surface of the medium. The first observation of male B. patulus was recorded under these conditions. It is presumed that these animals utilizing this resource were able to sustain themselves long enough for male production to occur. Consequently, to starve animals, antibiotics were added to the medium.

Figure 1: Incorporation Rate Experiment Apparatus

Figure 1 (Bennett 1977)

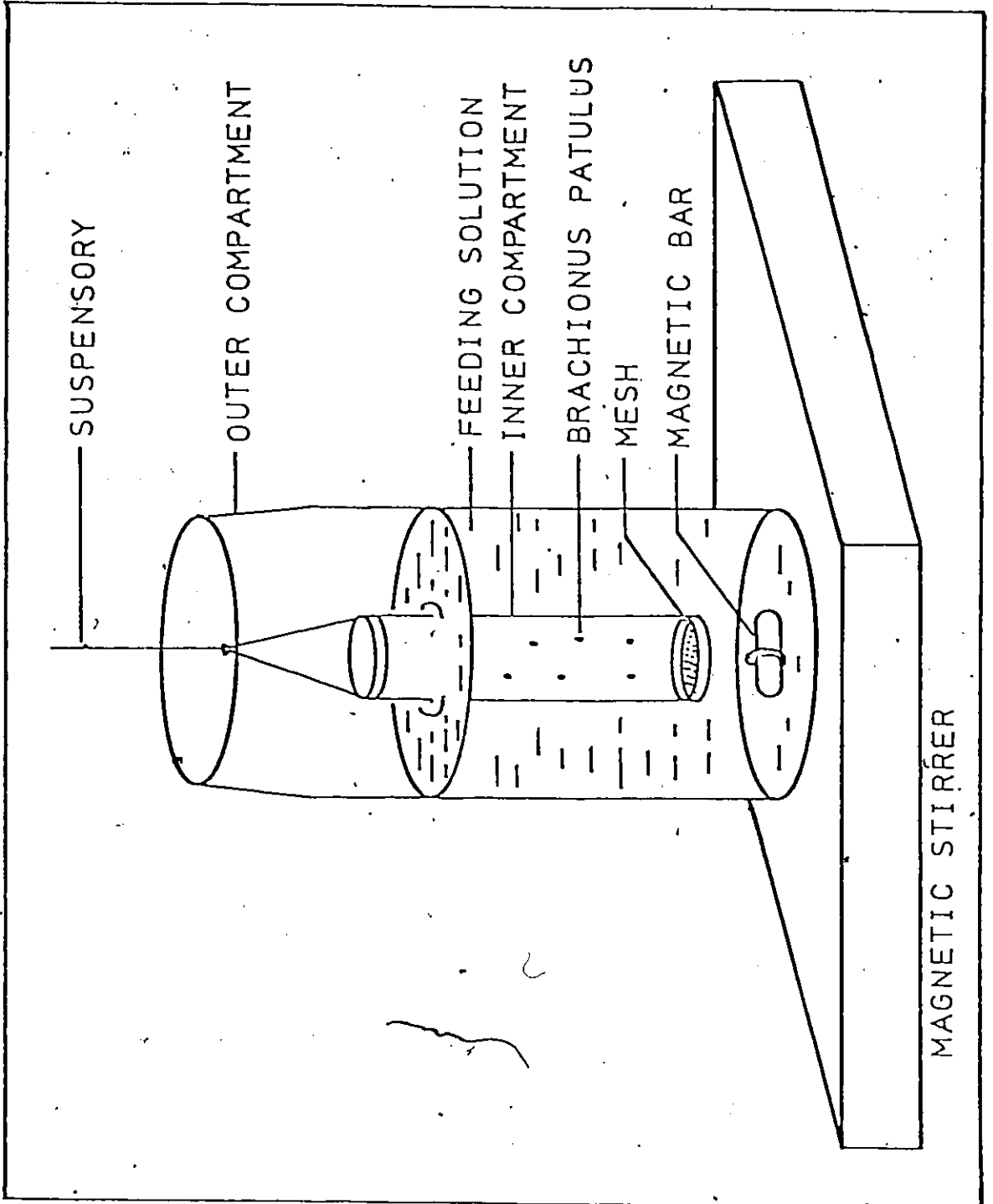

Table 1: Medium Manipulations for Intrinsic Rate of Increase Experiment.

Table 1

Treatment Number	Treatment
1	.5 ml <u>Chlamydomonas</u> Suspension .5 ml Bristol's Medium
2	.5 ml Aged Detritus Suspension .5 ml Bristol's Medium
3	.5 ml <u>Chlamydomonas</u> Suspension .5 ml Antibiotic Extract*
4	.5 ml Sterile Detritus Suspension .5 ml Bristol's Medium
5	.5 ml Antibiotic Extract* .5 ml Bristol's Medium
6	1 ml Bristol's Medium

* Filtrate of Sterile Detritus passed through a Sartorius membrane filter.

Table 2: Lifetime, Number of Eggs Females and Intrinsic Rate of Increase for Brachionus patulus Fed Various Food Types.

Table 2

Food Type	Number of Animals	Lifetime (days)	Number of Eggs Female ⁻¹	r
<u>Chlamydomonas</u>	8	11.86±.58	8.25±1.0	.358±.032
Aged Detritus	11	9.91±.80	1.55±.46	.044±.003
<u>Chlamydomonas</u> + Antibiotics	11	5.00±.75	0.46±.21	.001*
Sterile Detritus	13	1.27±.26	-	-
No Food + Antibiotics	10	0.90±.008	-	-

Figure 2: Death Rate Curves of Brachionus patulus Fed Various Foods.

x—x Sterile Detritus
0—0 Chlamydomonas and Antibiotics
+—+ Aged Detritus
— Chlamydomonas

Figure 2

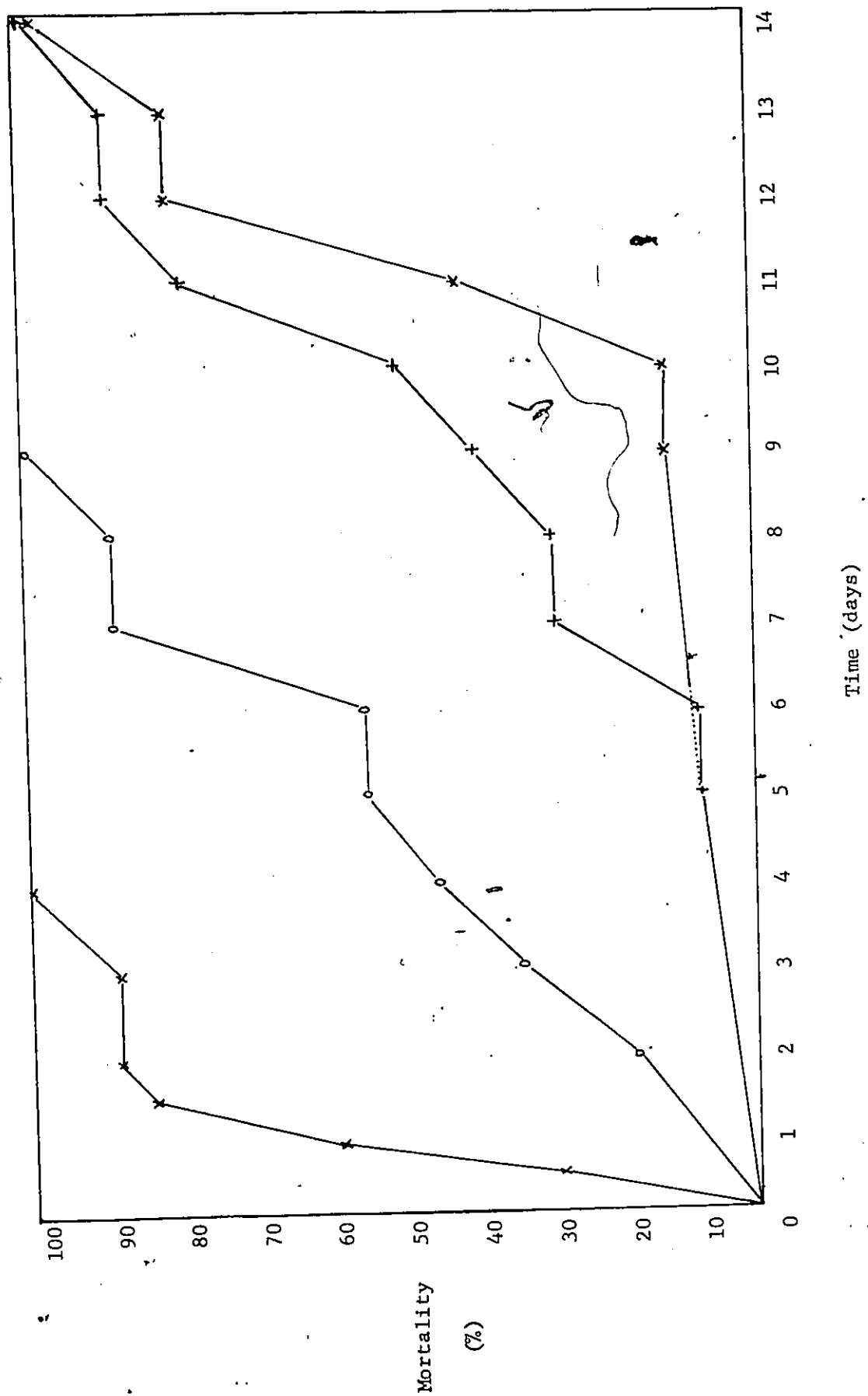

II EFFECTS OF ANTIBIOTICS ON INCORPORATION RATE

Given the marked decrease in lifetime of rotifers fed Chlamydomonas with antibiotic extract (5.0 days versus 11.86 days for rotifers fed algae alone)(Table 2) an experiment was performed to determine whether antibiotic toxicity was the cause of this observation.

METHODS

Seventy five animals were placed in each of two inner compartments and placed in treatment chambers. In one set of treatment chambers, 100 ml of ¹⁴C-labelled Chlamydomonas were added to 500 ml Bristol's medium. In the second group of chambers, antibiotics were also added. Triplicate samples were taken from each treatment chamber for POC determinations and a 1 ml sample was taken from each chamber for radioactivity determination. Incorporation rate was then measured according to the procedure outlined in the General Methods.

RESULTS

The rate of incorporation of Chlamydomonas with antibiotics present and absent are given in Table 3. There was no significant difference between the two sets of data ($F = 2.92$.10 p .25, n.s.).

Table 3: The Effects Of Antibiotics on Incorporation Rate of
Chlamydomonas by Brachionus patulus ($\mu\text{g C individual}^{-1} \text{h}^{-1}$).
Analysis of Variance F ratio = 2.92 (n.s.)

Table 3

Antibiotics Present	Antibiotics Absent
.01312	.01248
.00556	.00434
.01635	.00165
.01087	.00528

III SELECTION EXPERIMENTS

i) Suspended vs. Detrital Bacteria

The results from the Intrinsic Rate of Increase experiments indicate that detrital bacteria are an important alternate source of food in the absence of algae for B. patulus (Table 2). The following experiment was carried out to determine whether the attachment of bacteria to a detrital substrate was important in making that source of energy available, or if equal use could be made of suspended, unattached bacteria.

METHODS

Bacteria were labelled and attached to detrital particles as described in the General Methods. 200 ml of detritus suspension and 50 ml bacteria suspension were each added to two different chambers containing two compartments. The incorporation rate of these two food sources was then measured according to previously described techniques. The POC of the bacterial suspension was determined and the POC of detrital bacteria calculated according to the method outlined in the General Methods.

RESULTS

The incorporation rate of bacteria found in suspension and attached to detrital particles was found to be not significantly different ($F = .097$ $p < .05$, n.s.). There was no apparent preference for bacteria attached to detritus. The values obtained are found in Table 4.

ii) Algae vs. Detritus

This experiment was carried out to reinforce the result obtained

in the Intrinsic Rate of Increase experiment which indicated that algae was preferred food source for B. patulus.

METHODS

Algae and detritus were labelled as described in the General Methods. POC determinations were made directly for algae and indirectly for detritus through the approximation calculations outlined previously.

Eight chambers were set up containing two compartments. Algae and/or detritus were added to each. In four chambers, the detritus was labelled while in the other four chambers the algae were labelled. The concentration of the food types in each chamber are given in Table 5.

RESULTS

The incorporation rates of algae and detritus combined by Brachionus patulus are summarized in Table 6. In the controls, the incorporation rates were not significantly different when the animals were provided either Chlamydomonas or detritus as the ration ($F = .164$ $p < .05$, n.s.). However, when the two foods were combined, algae at all concentrations were incorporated at a rate not significantly different from the control ($F = .997$ $p < .05$, n.s.), whereas the incorporation rate of detritus drops significantly ($F = 227.9$ $p \ll .001$). Incorporation of detritus increases in Chamber 4 where 75 ml of detritus are combined with 25 ml algae in comparison to Chambers 2 and 3 which contain 25 and 50 ml of detritus and 75 and 50 ml of algae, respectively. ($SS = 1.6 \times 10^{-6}$ and $SS = 1.99 \times 10^{-6}$ respectively, $.01 < p < .025$). The uptake of ^{14}C in Chambers 2 and 3 was not significantly different ($SS = 2.1 \times 10^{-8}$ $p < .05$, n.s.). Chambers 2 and 4 (algae labelled) were not significantly

Table 4: The Incorporation Rate of Suspended Bacteria and
Bacteria Attached to Detrital Particles.

Analysis of Variance F ratio = .097 (n.s.)

Table 4 .

Suspended Bacteria	Detrital Bacteria
.00581	.00664
.00456	.00564
.00460	.00477
.00585	.00452

different from Chambers 2 and 4 (detritus labelled) at accepted levels (F = 8.95 $.05 < p < .1$, n.s. and F = 7.26 $.1 < p < .25$, n.s., respectively).

There was, however, a trend towards a difference in results indicating further support for the result that B. patulus does actually select for the preferred food type.

Table 5: Concentration of Food Types for Selection Experiments
(Algae versus Détritius).

Table 5

Chamber	Algae labelled	Detritus labelled
1	100 ml algae	100 ml detritus
2	75 ml algae/25 ml detritus	25 ml detritus/75 ml algae
3	50 ml algae/50 ml detritus	50 ml detritus/50 ml algae
4	25 ml algae/75 ml detritus	75 ml detritus/25 ml algae

Table 6: Incorporation Rate of Algae and Detritus in Mixed
Suspensions ($\mu\text{g C individual}^{-1}\text{h}^{-1}$).

Table 6

Chamber	Algae labelled	Treatment	Detritus labelled	Treatment
1	.00783	100 ml algae	.00644	100 ml detritus
2	.00576	75 ml algae +	.00631	25 ml detritus +
	.00486		.00149	
3	.00828	25 ml detritus	.00141	50 ml detritus +
	.00946	50 ml algae +	.00158	50 ml algae
4	.01032	50 ml detritus	.00104	75 ml detritus +
	.00359	25 ml algae +	.00257	25 ml algae
	.00455	75 ml detritus	.00286	

DISCUSSION

In this study it was shown that Brachionus patulus fed an algal diet demonstrated a higher rate of egg production than animals fed detritus (Table 2). Similar results were found by Heinle et al (1977) in the copepod Scottolana canadensis and Pilarska (1972) reported that algae-fed Brachionus rubens demonstrated better survivorship and fecundity and produced its first eggs at a younger age than those fed a bacterial diet.

Survivorship of B. patulus, however, was not significantly different whether the animal was fed aged detritus or algae (Table 2). The decreased survivorship reported by Pilarska when B. rubens was fed only bacteria may have been the result of using only a single species of bacteria, Aerobacter aerogenes whereas B. patulus received a natural microbial population which also included protozoans.

Although the possibility exists that B. patulus may derive nutritive value from detrital particles *per se*, present data do not support this (Table 2). The fact that longevity of starved animals (cultured in sterile Bristol's medium) was not significantly different from animals fed sterile detritus indicates that a source of nourishment was not present.

The above result may be confounded by the presence of the antibiotics necessary to produce sterile conditions in treatment chambers. While incorporation rates of algae by B. patulus were not affected by antibiotics with exposure times of four hours (Table 3), life table data indicate, however, that antibiotics exert a negative effect on the animals over longer exposure times (Table 2). This was demonstrated in Figure 1 where the first deaths occurred on day 2 in populations

exposed to algae-antibiotic mixtures. Intrinsic rate of increase experiments show that algae-fed animals were much more fit than animals fed algae in the presence of antibiotic extract.

The comparison of sterile detritus with aged detritus as a possible nutritional source is further confounded by the nature of the detrital particle after preparation. Aged detrital particles influenced by bacterial action may have had certain nutrients altered in this process rendering them readily digestible. Such action could not occur in sterile detritus preparations. If this were an important process, the difference between the two detrital particles would be greater than simply the presence or absence of bacteria. To circumvent this problem, both particles could be colonized initially. One group would then be sterilized for use in the experiments as the sterile ration. The problem arises, however, in that dead, attached microbes, rather than the particle itself, may provide nutrition to the animal.

Ideally, the need for sterile conditions to monitor the incorporation of detrital particles should be eliminated. To this end, attempts at labelling plant tissue to carry out incorporation rate experiments on detrital particles were made, but were unsuccessful. Techniques for incorporating label into plant structural tissues are necessary to determine definitively whether or not detritus particles are digested directly by B. patulus.

Selection experiments indicate that algae is actively chosen over detritus as a source of food when both are present (Table 6). However, algae and bacteria attached to algae-sized particles were found to be incorporated at similar rates when each food type was offered to B. patulus as the sole food source. Assuming that both food types are

assimilated with equal efficiency, these results indicate that B. patulus is capable of ingesting algal cells and detrital particles at equal rates.

When the two food sources are mixed in a 1:1 ratio, however, the incorporation rate of algae remains unchanged from the control while the incorporation of detritus drops to less than 20% of control rates. When detritus and algae are found in a 3:1 ratio, the incorporation rate of algae is not significantly different from the control whereas detritus is only incorporated at a rate 50% of the control. Different species of algae other than Chlamydomonas are incorporated at different rates by B. patulus (Bennett 1977) and therefore, could possibly yield different results.

Whether selection occurs at the level of ingestion or assimilation is not proven in these experiments. The cues a rotifer receives from different food particles and the anatomical features responsible for reception of those cues is also not known.

Gilbert and Starkweather (1977) have demonstrated three ways in which Brachionus calyciflorus can select and reject food particles. The first mechanism involves the folding of the pseudotrochal cirri over the buccal field to form a screen capable of blocking the passage of very small particles. The second method by which particles can be selected is by a change in the ciliary beat of the buccal field, thereby expelling unwanted particles through the ventral cleft of the funnel before they reach the oral canal. The third technique B. calyciflorus uses in rejecting particles is to expel unwanted particles which have already entered the oral canal with the jaws. This material is then swept away by ciliary action in the buccal field.

The fact that detrital bacteria and algae are assimilated at equal rates when found alone indicates that selection occurs before the food enters the gut. Selection must occur at the ingestion level, probably using at least one of Gilbert and Starkweather's mechanisms. The fact that food particle size cannot, in these experiments, be used as a selection criterion, indicates selection probably occurs in the buccal field and/or oral canal.

Lenz (1977) assumes that phytoplankton and detritus are ingested in proportions equal to the amounts of each found at a particular time. This is based on the assumption that filter feeders cannot qualitatively distinguish between similar sized phytoplankton and detrital particles. In the case of B. patulus, this assumption can now be challenged since selective ability has been clearly demonstrated by this rotifer:

The fact that algal food sources are selected over bacterial sources may be explained on the basis of attributes of both food types. Pilarska (1972) feels that bacteria have a negative effect caused by metabolic byproducts. Heinle et al (1977) suggest the presence of some trace metabolite in algae not found in bacterial cells is essential to egg production. Based on the results of the Intrinsic Rate of Increase experiments (Table 2), Heinle's theory seems to be the most probable. While survivorship is not affected negatively by bacterial food, egg production is affected by the absence of algae.

The fact that B. patulus was able to incorporate bacteria equally well when the cells were attached to a detrital substrate or in suspension (Table 4) indicates the wide range of food particles that may be available to this suspension feeder.

LITERATURE CITED

- Adams, S.M. and J.W. Angelovic. 1971. Assimilation of detritus and its associated bacteria by three species of estuarine animals. *Chesapeake Sci.* 11:249-254.
- Baylór, E.R., W.H. Sutcliffe and D.S. Hirschfield. 1962. Adsorption of phosphate onto bubbles. *Deep-Sea Research* 9:120-124.
- Bennett, R.W. 1977. Rates of incorporation of ^{14}C and size selection by Brachionus patulus Muller 1786. M.Sc. Thesis, Univ. of Windsor (Can.), 73 p.
- Bevan, L. 1977. Some factors affecting the incorporation rates of Simocephalus vetulus Schodler (Crustacea, Cladocera). M.Sc. Thesis, Univ. of Windsor (Can.), 67 p.
- Dumont, H.J. 1977. Biotic factors in the population dynamics of rotifers. *Arch. Hydrobiol. Beih. Ergebn. Limnol.* 8:98-122.
- Fenchel, T. 1970. Studies on the decomposition of organic detritus derived from the turtle grass Thalassia testudinum. *Limnol. Oceanogr.* 15:14-20.
- Finenko, Z.Z. and V.E. Zaika. 1970. Particulate organic matter and its role in the productivity of the sea, p. 32-44. In J.H. Steele (ed.) *Marine Food Chains*. Univ. California Press, Berkeley.
- Francisco, D.E., R.A. Mah and A.C. Rabin. 1973. Acridine orange-epifluorescence technique for counting bacteria in natural waters. *Trans. Amer. Micros. Soc.* 92:416-421.
- Gilbert, J.J. and P.L. Starkweather. 1977. Feeding in the rotifer Brachionus calyciflorus I. Regulatory mechanisms. *Oecologia* 28:125-131.
- Golterman, H.L. 1972. The role of phytoplankton in detritus formation. *Mem. Ist. Ital. Idrobiol.* 29(Supl.):89-103.

- Harrison, P.G. and K.H. Mann. 1975b. Detritus formation from eelgrass (Zostera marina). The relative effects of fragmentation, leaching and decay. *Limnol. Oceanogr.* 20:924-934.
- Heinle, D.R. and D.A. Flemer. 1975. Carbon requirements of a population of the estuarine copepod Eurytemora affinis. *Mar. Biol.* 31:235-247.
- Heinle, D.R., R.P. Harris, J.F. Ustach and D.A. Flemer. 1977. Detritus as a food for estuarine copepods. *Mar. Biol.* 40:341-353.
- James, D.E. 1974. Culturing algae. Carolina Biological Supply Company. Burlington, North Carolina. 23 p.
- Johannes, R.E. and M. Satomi. 1966. Composition and nutritive value of fecal pellets of a marine crustacean. *Limnol. Oceanogr.* 11:191-197.
- King, C.E. 1967. Food, age and the dynamics of a laboratory population of rotifers. *Ecology* 48:111-128.
- Knauer, G.A. and A.V. Ayers. 1977. Changes in carbon, nitrogen, ATP and Chlorophyll a in decomposing Thalassia testudinum leaves. *Limnol. Oceanogr.* 22:408-414.
- Lampert, W. 1974. A method for determining food selection by zooplankton. *Limnol. Oceanogr.* 19:995-998.
- Lenz, J. 1977. On detritus as a food source for pelagic filter feeders. *Mar. Biol.* 41:39-48.
- Lopez, G.R., J.S. Levinton and L.B. Slobodkin. 1977. The effect of grazing by the detritivore Orchestia grillus on Spartina litter and its associated microbial community. *Oecologia* 30:111-128.
- Mann, K.H. 1972. Macrophyte production and detritus food chains in coastal waters. *Mem. Ist. Ital. Idrobiol.* 29(Supl.):353-383.

- Mullin, M.M. and E.R. Brooks. 1967. Laboratory culture, growth rate and feeding behaviour of a planktonic marine copepod. *Limnol. Oceanogr.* 12:657-666.
- Newell, R. 1965. The role of detritus in the nutrition of two marine deposit feeders. *Zool. Soc. Lond., Proc.*, 144:25-45.
- Odum, E.P. and A.A. de la Cruz. 1963. Detritus as a major component of ecosystems. *AIBS Bulletin* 13:39-40.
- Odum, E.P. and A.A. de la Cruz. 1967. Particulate organic detritus in a Georgia salt marsh-estuarine ecosystem, p. 383-388. In G.H. Lauff (ed.) *Estuaries*. Amer. Assoc. Adv. Sc. Publ. No. 83.
- Olah, J. 1972. Leaching, colonization and stabilization during detritus formation. *Mem. Ist. Ital. Idrobiol.* 29(Supl.):105-127.
- Pennington, W. 1942. The control of the number of freshwater phytoplankton by small invertebrate animals. *J. Anim. Ecol.* 11:204-211.
- Pilarska, J. 1973. The dynamics of growth of experimental populations of the rotifer Brachionus rubens. *Pol. Arch. Hydrobiol.* 19:265-277.
- Povoledo, D. 1972. Some model experiments on detritus formation and on some possible functions of suspended and deposited lake organic matter. *Mem. Ist. Ital. Idrobiol.* 29(Supl.):485-523.
- Rigler, F.H. 1971. Methods for the measurement of assimilation of food by zooplankton, p. 264-269. In W.T. Edmondson and G.C. Winberg (ed.) *A manual on methods for the assessment of secondary productivity in fresh waters*. IBP Handbook 17. Blackwell Scientific Publications, Oxford and Edinburgh.
- Riley, G. 1963. Organic aggregates in seawater and the dynamics of their formation and utilization. *Limnol. Oceanogr.* 8:372-381.
- Rodina, A.G. 1964. Microbiology of detritus of lakes. *Limnol. Oceanogr.* 8:388-393.

- Rodina, A.G. 1966. Variety and destruction of lake detritus. *Vehe. int. Ver. Limnol.* 16:1513-1517.
- Ruttner, F. 1952. *Fundamentals of Limnology*. Univ. Toronto Press. 307 p.
- Saunders, G.W. 1972. The transformation of artificial detritus in lake water. *Mem. Ist. Ital. Idrobiol.* 29(Supl.):261-288.
- Sokal, R.R. and F.J. Rohlf. 1969. *Biometry*. W.H. Freeman and Co. 766 p.
- Sorokin, Y.J. 1966. Carbon-14 method in the study of the nutrition of aquatic animals. *Int. Rev. Gesamten. Hydrobiol.* 51:209-224.
- Steele, J.H. and I.E. Baird. 1972. Sedimentation of organic matter in a Scottish sea loch. *Mem. Ist. Ital. Idrobiol.* 29(Supl.):73-88.
- Strickland, J.D.H. and T.R. Parsons. 1968. *A practical handbook of seawater analysis*. *Bull. Fish. Res. Bd. Can.* 122. 172 p.
- Tenore, K.R. 1977. Utilization of aged detritus derived from different sources by the polychaete Capitella capitata. *Mar. Biol.* 44:51-55.
- Wetzel, R.G., P.H. Rich, M.C. Miller and H.L. Allen. 1972. Metabolism of dissolved and particulate detrital carbon in a temperate hard-water lake. *Mem. Ist. Ital. Idrobiol.* 29(Supl.):185-243.

VITA AUCTORIS

Born:

June 9, 1955. Windsor, Ontario

Son of Mr. and Mrs. Robert Owen

Elementary Education:

St. Hubert Separate School, Windsor, Ontario

Secondary Education:

Vincent Massey Secondary School, Windsor, Ontario

University Education:

Department of Biology, University of Windsor

Degree: Bachelor of Science